

KIPOR

KIPOR POWER

OPERATION MANUAL

PLEASE READ THIS MANUAL CAREFULLY.
IT CONTAINS IMPORTANT SAFETY INFORMATION.

WWW.KIPOR.COM

KIPOR

WUXI KIPOR POWER CO., LTD.

Address: Beside Jingyi Rd, Third-stage Development Section
of Wangzhuang Industry Area, Wuxi High &
New Technology Industry Development Zone.

TEL: 0086-510-85200888

FAX: 0086-510-85200999

E-MAIL: kipor@kipor.com

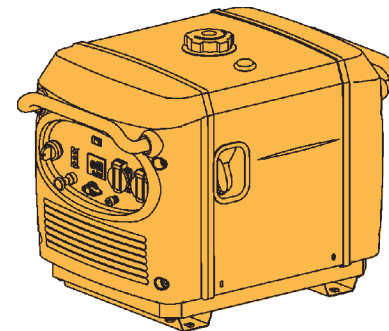

SINEMASTER
DIGITAL GENERATOR

IG3000

IGLB3000

Version 3, Printing date 20/12/2005

PREFACE

Thank you for purchasing a our generators.

This manual covers operation and maintenance of the IG3000, IGLB3000 generator.

All information in this publication is based on the latest product information available at the time of approval for printing.

We reserves the right to make changes at any time without notice and without incurring any obligation.

No part of this publication may be reproduced without written permission.

This manual should be considered a permanent part of the generator and should remain with it if it is resold.

Pay special attention to statements preceded by the following words;

WARNING

Failure to properly follow these precautions can result in property damage, serious injury or DEATH!

Read all labels and the owner's manual before operating this generator.

Operate only in well ventilated areas. Exhaust gas contains poisonous carbon monoxide, and can be deadly. Always stop engine before refueling. Wait 5 minutes before restarting.

Check for spilled fuel or leaks. Clean and/or repair before use.

Keep any sources of ignition away from fuel tank, at all times.

WARNING

Indicates a strong possibility of severe personal injury or death if instructions are not followed.

CAUTION

Indicates a possibility of personal injury or equipment damage if instructions are not followed.

NOTE: Gives helpful information.

If a problem should arise, or if you have any questions about the generator, consult an authorized dealer.

WARNING

Our generators are designed to give safe and dependable service if operated according to instructions. Read and understand the Owner's Manual before operating the generator. Failure to do so could result in personal injury or equipment damage.

CONTENTS

1.SAFETY INSTRUCTIONS.....	1
2.SAFETY LABEL LOCATIONS.....	3
3.PRE-OPERATION CHECK.....	5
4.STARTING THE ENGINE	8
5.GENERATOR USE	11
6.STOPPING THE ENGINE.....	14
7.MAINTENANCE	15
8.TRANSPORTING/STORAGE.....	22
9.TROUBLESHOOTING	23
10.SPECIFICATIONS.....	25
11.WIRING DIAGRAM.....	26
12.FIXING PICTURE OF CASTER	27

1. SAFETY INSTRUCTIONS

WARNING



- Our generators are designed to give safe and dependable service if operated according to instructions. Read and understand the Owner's Manual before operating the generator. Failure to do so could result in personal injury or equipment damage.

WARNING



- Exhaust gas contains poisonous carbon monoxide. Never run the generator in an enclosed area. Be sure to provide adequate ventilation. When installed in ventilated protection are to be observed.

WARNING



- The muffler becomes very hot during operation and remains hot for a while after stopping the engine. Be careful not to touch the muffler while it is hot. Let the engine cool before storing the generator indoors. The engine exhaust system will be heated during operation and remain hot immediately after stopping the engine. To prevent scalding, pay attention to the warning marks attached to the generator.

CAUTION



- Never connect a cable other than the special cable for parallel operation to the parallel operation socket. Electric shocks can result if this instruction is not followed.

To ensure safe operation--

⚠ WARNING

- Gasoline is extremely flammable and explosive under certain conditions. Refuel in a well ventilated area with the engine stopped.
- Keep away from cigarette, smoke and sparks when refueling the generator. Always refuel in a well-ventilated location.
- Wipe up spilled gasoline at once.

⚠ WARNING



- Connections for standby power to a building's electrical system must be made by a qualified electrician and must comply with all applicable laws and electrical codes. Improper connections can allow electrical current from the generator to back feed into the utility lines. Such back feed may electrocute utility company workers or others who contact the lines during a power outage, and when utility power is restored, the generator may explode, burn, or cause fires in the building's electrical system.

⚠ WARNING

- Always make a pre-operation inspection before you start the engine. You may prevent an accident or equipment damage.
- Place the generator at least 1m(3ft) away from buildings or other equipment during operation.
- Operate the generator on a level surface. If the generator is tilted, fuel spillage may result.
- Know how to stop the generator quickly and understand operation of all the controls. Never permit anyone to operate the generator without proper instructions.
- Keep children and pets away from the generator when it is in operation.
- Keep away from rotating parts while the generator is running.
- The generator is a potential source of electrical shocks when misused; do not operate with wet hands.
- Do not operate the generator in rain or snow and do not let it get wet.

2.SAFETY LABEL LOCATIONS

2.1 Outside view

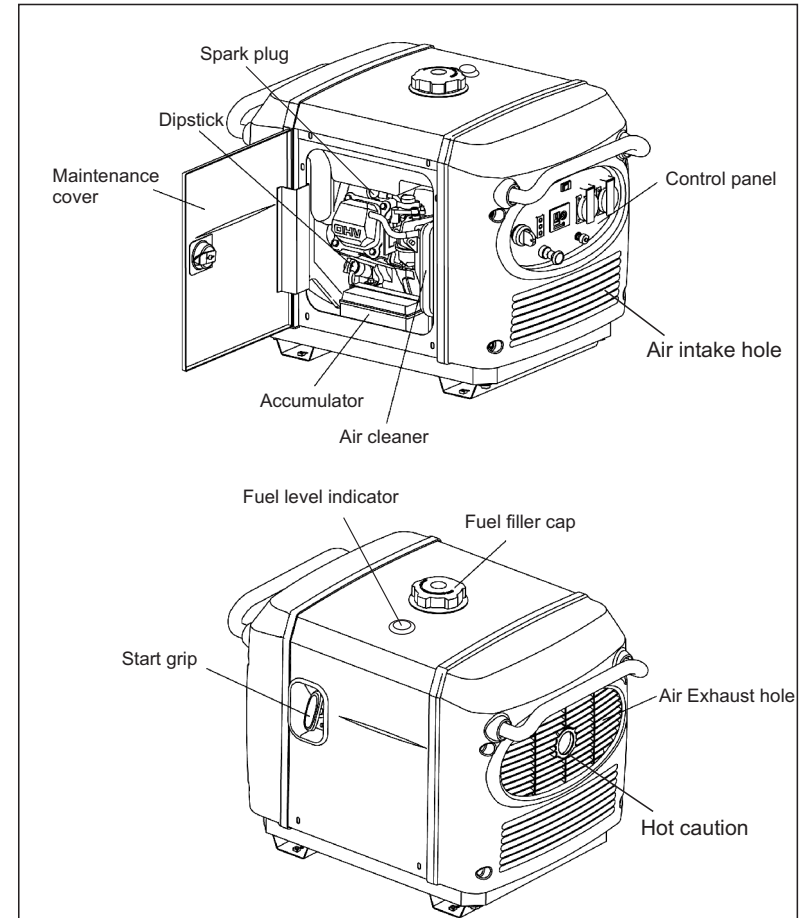

Fig1. Outside view

2.2 Control panel

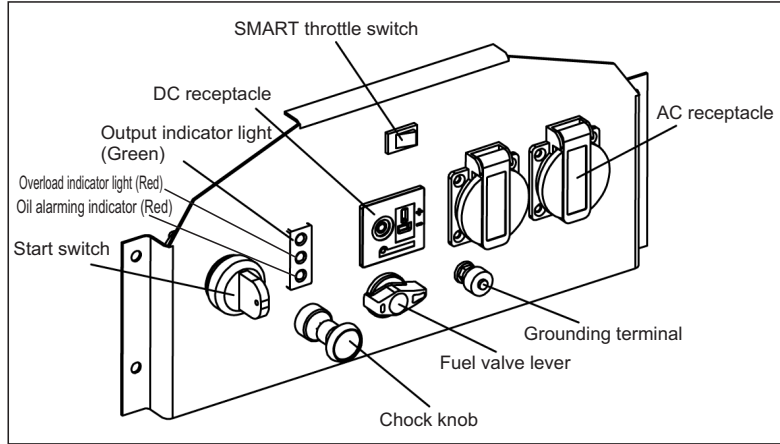

Fig 2. Control panel

2.3 SMART throttle

Engine speed is kept at idle automatically when the electrical appliance is disconnected and it returns to the proper speed by the electrical load when electrical appliance is connected. This position is recommended to minimize the fuel consumption while in operation

NOTE

- When high electrical load appliances are connected simultaneously, turn the smart throttle switch to the OFF position to reduce voltage changes.
- Smart throttle system does not operate sufficiently if the electrical appliance requires the much electric power.

OFF:

SMART throttle system does not operate. Engine speed is kept over rated speed.

3. PRE-OPERATION CHECK

Be sure to check the generator on a level surface with the engine stopped.

3.1 Check the engine oil level.

CAUTION

- Using nondetergent oil or 2-stroke engine oil could shorten the engine's service life.
- Use high-detergent, premium quality 4-stroke engine oil, certified to meet or exceed U.S. automobile manufacturer's requirements for API Service Classification SG,SF.
- Select the appropriate viscosity for the average temperature in your area

SAE Viscosity Grades

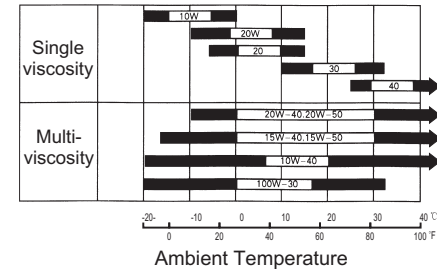

Open the oil maintenance cover. Remove the oil filler cap, and wipe the dipstick with a clean rag. Check the oil level by inserting the dipstick in the filler hole without screwing it in. If the oil level is below the end of the dipstick, refill with recommended oil up to the top of the oil filler neck.

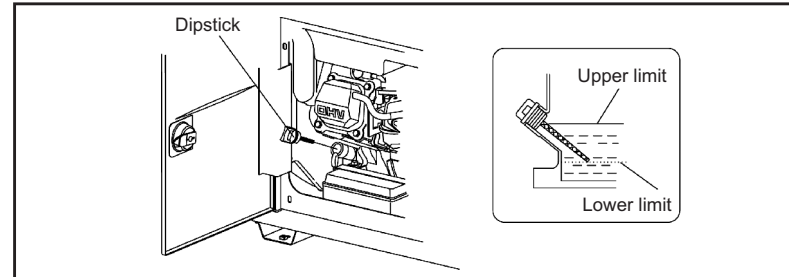

Fig.3

⚠ CAUTION

- Running the engine with insufficient oil can cause serious engine damage.
- The Low Oil Alarm System will automatically stop the engine before the oil level falls below the safe limit. However, to avoid the inconvenience of an unexpected shutdown, it is still advisable to visually inspect the oil level regularly.

3.2 Check the fuel level

Use automotive gasoline (Unleaded or lowleaded is preferred to minimize combustion chamber deposits).

If the fuel level is low, refill to the shoulder of the fuel strainer, see fig. 4.

Never use an oil/gasoline mixture or dirty gasoline.

Avoid getting dirt, dust or water in the fuel tank.

After refueling, tighten the fuel filler cap securely.

⚠ WARNING

- Gasoline is extremely flammable and is explosive under certain conditions.
- Refuel in a well-ventilated area with the engine stopped. Do not smoke or allow flame or sparks in the area where the engine is refueled or where gasoline is stored.
- Do not overfill the fuel tank (there should be no fuel in the filler neck). After refueling, make sure the fuel filler cap is closed properly and securely.
- Be careful not to spill fuel when refueling. Spilled fuel or fuel vapor may ignite.
If any fuel is spilled, make sure the area is dry before starting the engine.
- Avoid repeated or prolonged contact with skin or breathing of vapor. KEEP OUT OF REACH OF CHILDREN.

Fuel tank capacity: 13L

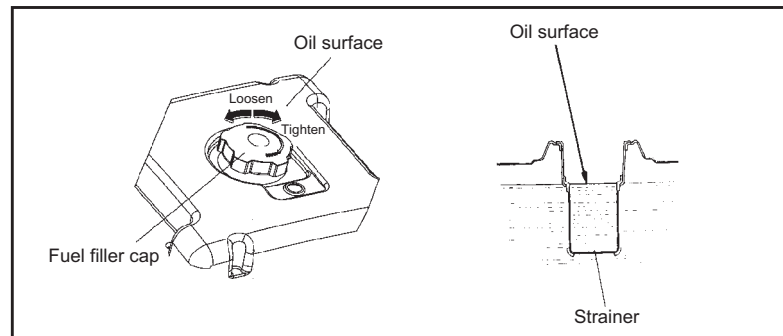

Fig.4

Gasolines containing alcohol

If you decide to use a gasoline containing alcohol (gasohol), be sure its octane rating is at least as high as that recommended by us. There are two types of "gasohol": one containing ethanol, and the other containing methanol. Do not use gasohol that contains more than 10% ethanol. Do not use gasoline containing methanol (methyl or wood alcohol) that does not also contain cosolvents and corrosion inhibitors for methanol. Never use gasoline containing more than 5% methanol, even if it has cosolvents and corrosion inhibitors.

⚠ NOTE

- Fuel system damage or engine performance problems resulting from the use of fuels that contain alcohol is not covered under the warranty. We cannot endorse the use of fuels containing methanol since evidence of their suitability is as yet incomplete.
- Before buying fuel from an unfamiliar station, try to find out if the fuel contains alcohol, if it does, confirm the type and percentage of alcohol used. If you notice any undesirable operating symptoms while using a gasoline that contains alcohol, switch to gasoline that you know does not contain alcohol.

3.3 Check the air cleaner

Check the air cleaner elements to be sure they are clean and in good condition. Open the left side maintenance cover. Remove the air cleaner cover, remove the paper element from the air cleaner cover, and check the both elements, clean or replace the element(s) if necessary, see fig.5.

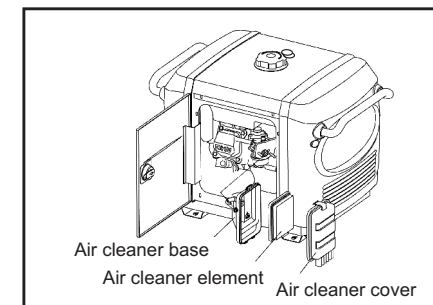

Fig. 5

⚠ CAUTION

- Never run the engine without the air cleaner. Rapid engine wear will result from contaminants, such as dust and dirt, being drawn through the carburetor, into the engine.

4. STARTING THE ENGINE

⚠ CAUTION

- When starting the generator after adding fuel for the first time, after longterm storage, or after running out of fuel, turn the fuel valve lever to the "ON" position, then wait for 10 to 20 seconds before starting the

4.1 Turn the fuel valve lever to the ON position, see fig.6.

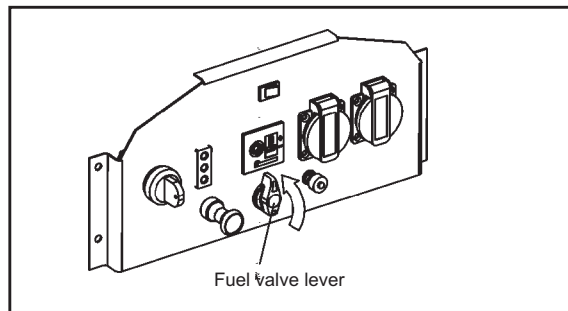

Fig.6

4.2 Pull the choke knob out to the CLOSED position

Do not use the choke when the engine is warm or the air temperature is high, see fig.7.

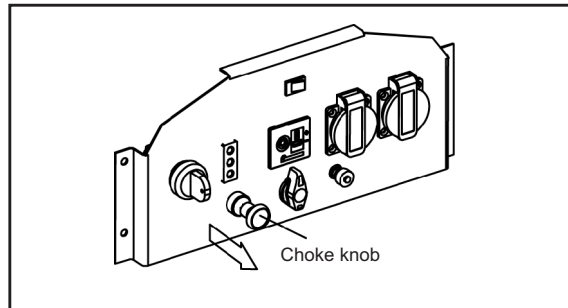

Fig.7

4.3 Insert the engine key, and turn the engine switch to ON position.

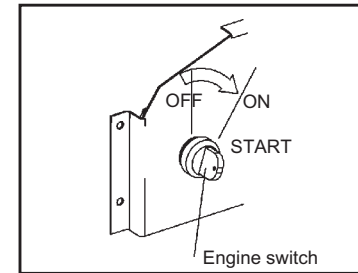

Fig.8

4.4(a) Turn the engine switch to the START until the engine has started, see Fig.9(a).

4.4(b) Pull the starter grip lightly until resistance is felt, then pull the starter grip briskly toward the arrow as shown below, see Fig. 9(b).

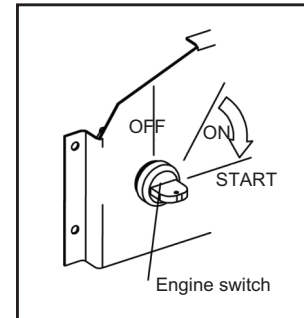

Fig.9(a)

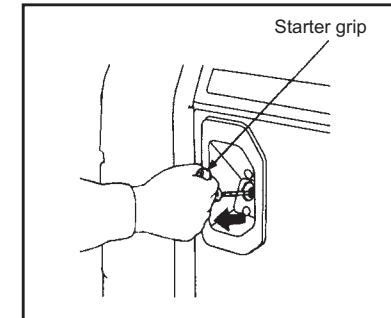

Fig.9(b)

⚠ CAUTION

- Do not allow the starter grip to snap back. Return it slowly by hand.
- Do not let the starter rope rub against the generator body or the rope will wear out prematurely.

4.5 Push the choke knob to the OPEN position as the engine warms up, see page 10.

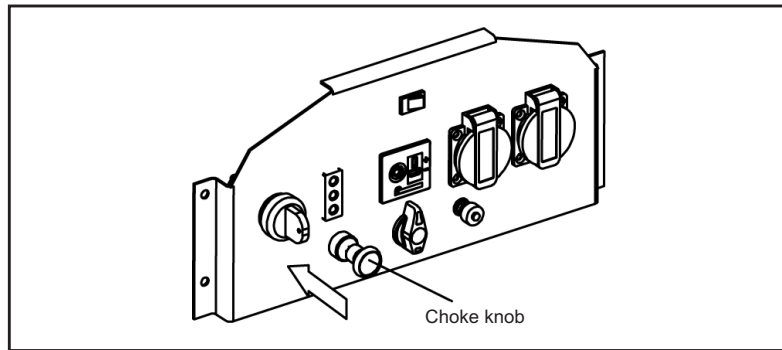

Fig.10

High altitude operation

At high altitude, the standard carburetor air-fuel mixture will be excessively rich. Performance will decrease, and fuel consumption will increase.

High altitude performance can be improved by installing a smaller diameter main fuel jet in the carburetor and readjusting the pilot screws. If you always operate the generator at altitudes higher than 1,500 m (5,000 feet) above sea level, have your authorized dealer perform these carburetor modifications.

Even with suitable carburetor jetting, engine horsepower will decrease approximately 3.5% for each 305 m (1,000 feet) increase in altitude. The effect of altitude on the horsepower will be greater than this if no carburetor modification is made.

⚠ CAUTION

- Operation of the generator at an altitude lower than the carburetor is jetted for may result in reduced performance, overheating, and serious engine damage caused by an excessively lean air/fuel mixture.

5.GENERATOR USE

⚠ WARNING

- To prevent electrical shock from faulty appliances, the generator should be grounded. Connect a length of heavy wire between the generator's ground terminal and an external ground source.
- Connections for standby power to a building's electrical system must be made by a qualified electrician and must comply with all applicable laws and electrical codes. Improper connections can allow electrical current from the generator to backfeed into the utility lines. Such backfeed may electrocute utility company workers or others who contact the lines during a power outage, and when utility power is restored, the generator may explode, burn, or cause fires in the building's electrical system.

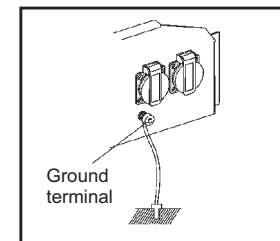

⚠ CAUTION

- Limit operation requiring maximum power to 30 minutes. For continuous operation do not exceed the rated power. In either case, the total wattage of all appliances connected must be considered.
- Do not exceed the current limit specified for any one receptacle.
- Do not connect the generator to a household circuit. This could cause the damage to the generator or to electrical appliances in the house.
- Do not modify or use the generator for other purposes than it is intended for. Also observe the following when using the generator.
 - Do not connect generators in parallel.
 - Do not connect an extension to the exhaust pipe.
- When an extension cable is required, be sure to use tough rubber sheathed flexible cable.
- Limit length of extension cables; 60 m for cables if 1.5mm² and 100m for cables of 2.5 mm².
- Keep the generator away from other electric cables or wires such as commercial power supply lines.

5.1 AC applications

1. Start the engine and make sure the output indicator light (green) comes on.
2. Confirm that the appliance to be used is switched off, and plug in the appliance.

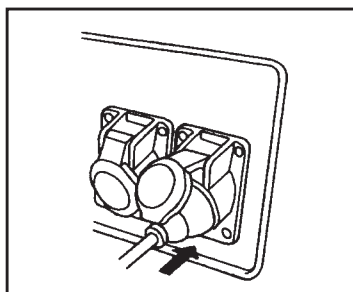

Fig. 12

⚠ CAUTION

- Substantial overloading that continuously lights the overload indicator light (red) may damage the generator. Marginal overloading that temporarily lights the overload indicator light (red) may shorten the service life of the generator.
- Be sure that all appliances are in good working order before connecting them to the generator. If an appliance begins to operate abnormally, becomes sluggish, or stops suddenly, turn off the generator engine switch immediately. Then disconnect the appliance and examine it for signs of malfunction.

5.2 Output and Overload Indicators

The out indicator light (green) will remain ON during normal operating conditions. If the generator is overloaded, or if there is a short in the connected appliance, the output indicator light (green) will go OFF, the overload indicator light (red) will go ON and current to the connected appliance will be shut off.

Stop the engine if the overload indicator light (red) comes ON and investigate the overload source.

Check engine oil if the oil alarming indicator (Red) Comes ON.

⚠ NOTE

- Before connecting an appliance to the generator, check that it is in good order, and that its electrical rating does not exceed that of the generator. Then connect the power cord of the appliance, and start the engine.

⚠ NOTE

- When an electric motor is started, both the overload indicator light (red) and the output indicator light (green) lights may go on simultaneously. This is normal if the overload indicator light (red) goes off after about four (4) seconds. If the overload indicator light (red) stays on, consult your dealer.

5.3 DC application

The DC receptacle may be used for charging 12 volt automotive-type batteries only. Output voltage is 15-30V when current receptacle on no load. DC output will vary according to the position of the Smart throttle switch. When the Smart throttle switch is turned to the ON position and the AC output is not used, the DC current will be about one-third of the rated current.

DC current:

SMART throttle switch Model	OFF	ON (do not use the AC output)
IG3000	8.3A	approximately 2.8A

1. Connect the charging cable to the DC receptacle of the generator and then to the battery terminals.

⚠ WARNING

- To prevent the possibility of creating spark near the battery, connect charging cable first to the generator, then to the battery. Disconnect cable first at the battery.
- Before connecting charging cable to a battery that is installed in a vehicle, disconnect the vehicle's grounded battery cable. Reconnect the vehicle's grounded battery cable after the charging cables are removed. This procedure will prevent the possibility of a short circuit and sparks if you make accidental contact between a battery terminal and the vehicle's frame or body.

⚠ CAUTION

- Do not attempt to start an automobile engine with the generator still connected to battery. The generator may be damaged.
- Connect the positive battery terminal to the positive charging cord. Do not reverse the charging cables, or serious damage to the generator and/or battery may occur.

⚠ WARNING

- The battery gives off explosive gases; keep sparks, flames and cigarettes away. Provide adequate ventilation when charging.
- The battery contains sulfuric acid (electrolyte). Contact with skin or eyes may cause severe burns. Wear protective clothing and a face shield.
 - A. If electrolyte gets on your skin, flush with water.
 - B. If electrolyte gets in your eyes, flush with water for at least 15 minutes and call a physician.
- Electrolyte is poisonous.
 - A. If swallowed, drink large quantities of water or milk and follow with milk of magnesia or vegetable oil and call a physician.
- Keep out of reach of children.

2. Start the engine

- The DC receptacle may be used while the AC power is in use.
- An overloaded DC circuit will trip the DC circuit protector (push button comes out).
If this happens, wait a few minutes before pushing in the circuit protector to resume operation.

6. STOP-ING THE ENGINE

To stop the engine in an emergency, turn the engine switch OFF.

In normal use:

1. Switch off the connected equipment and pull the inserted plug.
2. Turn off the engine switch.
3. Turn the fuel valve lever to the OFF position.

7. MAINTENANCE

The purpose of the maintenance and adjustment schedule is to keep the generator in the best operating condition.

⚠ WARNING

- Shut off the engine before performing any maintenance. If the engine must be run, make sure the area is well ventilated. The exhaust contains poisonous carbon monoxide gas.

⚠ CAUTION

- Use genuine our parts or the equivalent. The use of replacement parts which are not of equivalent quality may damage the generator.

Maintenance Schedule

REGULAR SERVICE PERIOD (1) Perform at every indicated month or operating hour interval, whichever occurs first		EACH USE	FIRST MONTH OR 20 HRS	EVERY 3 MONTHS OR 50 HRS	EVERY 6 MONTHS OR 100 HRS	EVERY YEAR OR 300 HRS
ITEM						
Engine oil	Check	○				
	Change		○		○	
Air cleaner	Check	○				
	Clean			○ (2)		
Spark plug	Clean-adjust				○	
Spark arrester	Clean				○	
Fuel sediment cup	Clean				○	
Valve clearance	Check-adjust					○ (3)
Fuel tank and strainer	Clean					○ (3)
Fuel line	Check	Every 2 years (Replace if necessary)(3)				

NOTE: (1) Log hours of operation to determine proper maintenance.

(2) Service more frequently when used in dusty areas.

(3) These items should be serviced by an authorized dealer, unless the owner has the proper tools and is mechanically proficient. See the Shop Manual.

7.2 Changing oil

Drain the oil while the engine is still warm to assure rapid and complete draining.

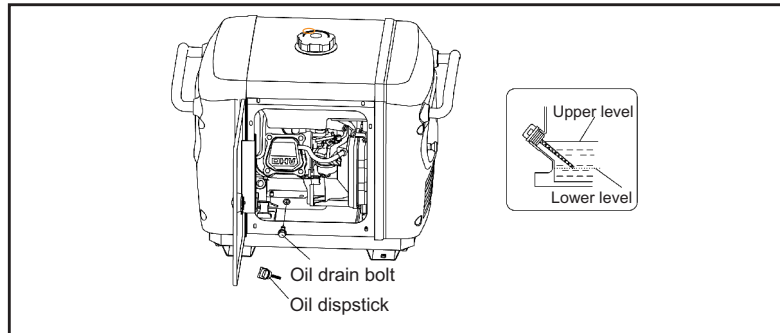

Fig.13

1. Open the left side maintenance cover.
2. Take out the oil outlet plug.
3. Remove the drain bolt, and drain the oil. Retighten the bolt securely.
4. Refill with the recommended oil and check the level.
5. Close the left side maintenance cover.

Engine oil capacity: 0.55L

NOTE

- Please dispose of used motor oil in a manner that is compatible with the environment. We suggest you take it in a sealed container to your local service station for reclamation. Do not throw it in the trash or pour it on the ground.

7.3 Air cleaner service

A dirty air cleaner will restrict air flow to the carburetor to prevent carburetor malfunction, service the air cleaner regularly. Service more frequently when operating the generator in extremely dusty areas.

WARNING

- Do not use gasoline or low flash point solvents for cleaning. They are flammable and explosive under certain conditions.

CAUTION

- Never run the generator without the air cleaner. Rapid engine wear may result

- 1.Revolve the left side cover knob, open the left side maintenance cover.
- 2.Unsnap the clips, remove the air cleaner cover.
- 3.Foam element:
 - Remove the foam element from the air cleaner cover.
 - Wash the foam element in a solution of household detergent and warm water, then rinse thoroughly, or wash in nonflammable or high flashpoint solvent. Allow the foam element to dry thoroughly.
 - Soak the foam element in clean engine oil and squeeze out the excess oil. The engine will smoke during initial startup if too much oil is left in the foam element.
 - Reinstall the foam element to the air cleaner cover.
4. Paper element: If the paper element is dirty, replace it with a new one. Do not clean the paper element.
- 5.Reinstall the air cleaner cover.
6. Close and latch the left side maintenance cover.

7.5 Spark plug service

Recommended spark plug: F6RTC

To ensure proper engine operation, the spark plug must be properly gapped and free of deposits.

1. Open the left side maintenance cover.
2. Remove the spark plug cap.
3. Use the wrench to remove the spark plug.
4. Clean any dirt from around the spark plug base.

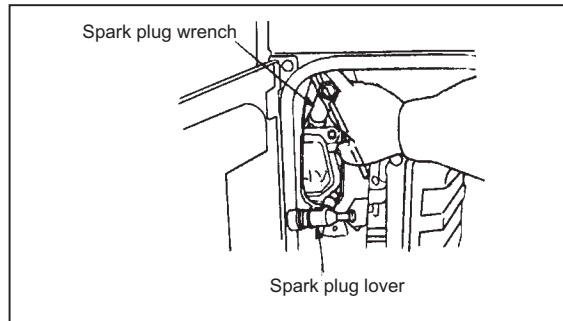

Fig.14

5. Visually inspect the spark plug. Discard it if the insulator is cracked or chipped. Clean the spark plug with a wire brush if it is to be reused.
6. Measure the plug gap with a feeler gauge. The gap should be 0.5-0.75mm(0.02-0.03in). Correct as necessary by carefully bending the side electrode.

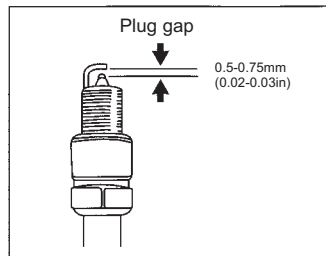

Fig. 15

7. Install the spark plug carefully, by hand, to avoid cross-threading.
 8. After a new spark plug has been seated by hand, it should be tightened 1/2 turn with a wrench to compress its washer.
- If a used plug is being reinstalled, it should only required 1/8 to 1/4 turn after being seated.
9. Reinstall the spark plug inspection cover and tighten the cover screw.
 10. Close and latch the left side maintenance cover.

CAUTION

- The spark plug must be securely tightened. An improperly tightened plug can become very hot and possibly damage the generator.
- Never use a spark plug with an improper heat range.

7.6 Spark arrester maintenance

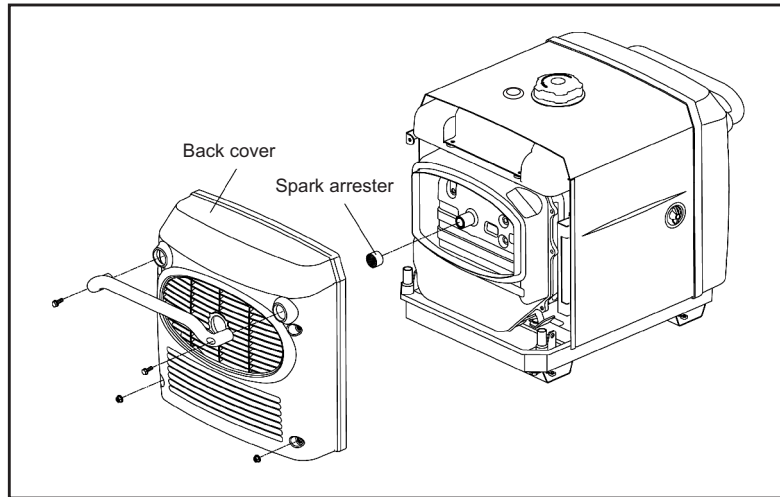

Fig. 16

⚠ WARNING

■ If the generator has been running, the muffler will be very hot. Allow it to cool before proceeding.

⚠ CAUTION

■ The spark arrester must be serviced every 100 hours to maintain its efficiency.

1. Remove the back cover.
2. Remove the exhaust tail pipe and spark arrester.
3. Use a brush to remove carbon deposits from the spark arrester screen.

⚠ NOTE

■ Inspect the spark arrester screen for holes or tears. Replace if necessary.

4. Reinstall the spark arrester.
5. Reinstall the upper back cover.

8. TRANSPORTING/STORAGE

8.1 When transporting the generator, turn the fuel valve lever OFF and keep the generator level to prevent fuel spillage. Fuel vapor or spilled fuel may ignite.

8.2 Before storing the unit for an extended period:

1. Be sure the storage area is free of excessive humidity and dust.

2. Drain the fuel—

a. Open the left side maintenance cover.

b. Turn fuel valve lever to ON and then loosen the carburetor drain screw. Drain the gasoline from the carburetor and fuel tank into a suitable container.

c. Tighten the carburetor screw, close the fuel valve lever and left side maintenance cover.

3. Once a month, recharge the battery.

4. Change the engine oil.

5. Remove the spark plug and pour about a tablespoon of clean engine oil into the cylinder. Crank the engine several revolutions to distribute the oil, then reinstall the spark plug.

6. Slowly pull the starter grip until resistance is felt. At this point, the piston is coming up on its compression stroke and both the intake and exhaust valves are closed.

Storing the engine in this position will help to protect it from internal corrosion.

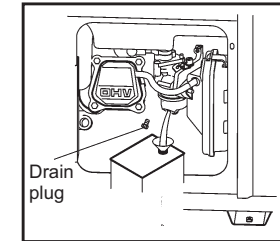
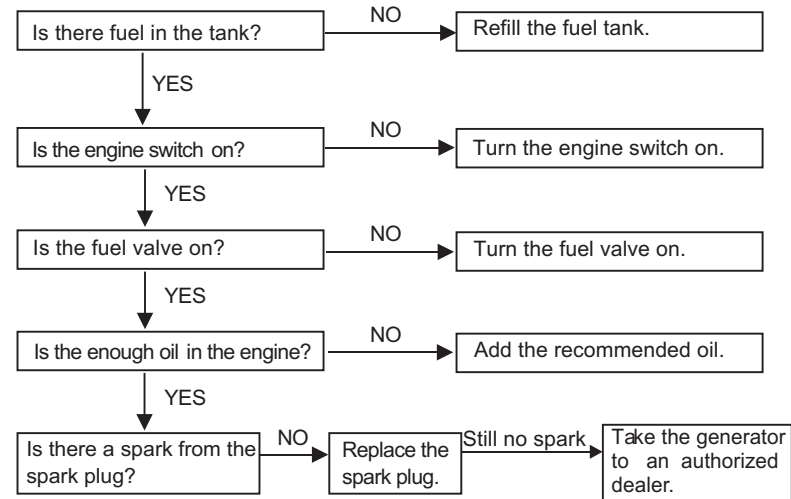

Fig. 17

9. TROUBLESHOOTING

When the engine will not start:



⚠ WARNING

- Be sure there is no spilled fuel around the spark plug. Spilled fuel may ignite.

Is the fuel reaching the carburetor?

If the engine still does not start, take the generator to an authorized dealer.

To check:

- Remove the spark plug cap and clean any dirt from around the spark plug.
- Remove the spark plug and install the spark plug in the plug cap.
- Set the plug side electrode on the cylinder head to ground.
- Crank the engine, sparks should jump across the gap.

To check:

- Turn off the fuel valve and loosen the drain screw.
- Fuel should flow from the drain when the fuel valve is turned on.

Appliance does not operate:

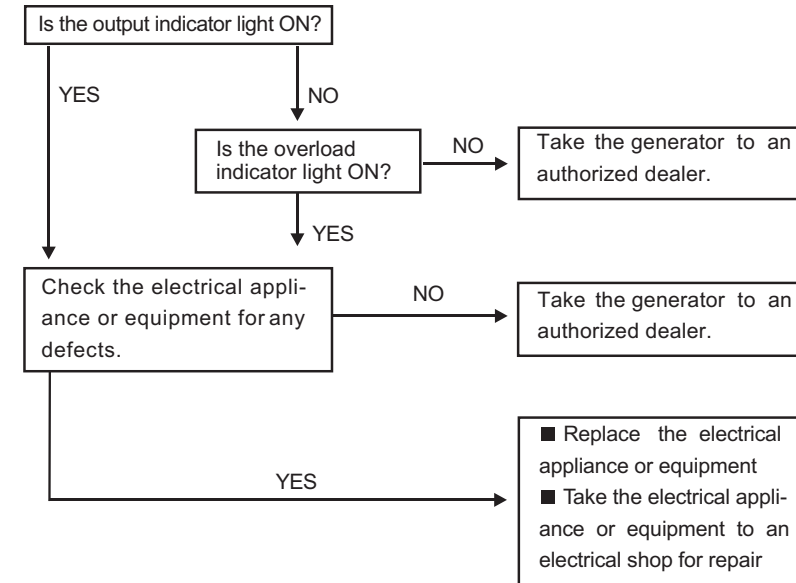

No electricity at the DC receptacle:

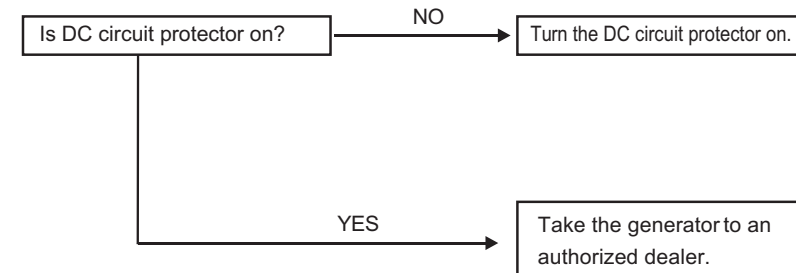

10. SPECIFICATIONS

Model	IG3000/IGLB3000		
Rated frequency (Hz)	50	60	60
Rated voltage (V)	230	120	240
Rated current (A)	12.2	23.3	11.7
Rated speed (rpm)	3600		
Rated output (kVA)	2.8		
Max output (kVA)	3.0		

DC output

DC voltage	12V-8.3A
Electric circuit breaker	Without
Phase number	Single phase

Engine

Model Type	KG205GTi
Type	Single cylinder, 4 stroke, vertical, air-cooled, OHV, gasoline engine
Displacement (Bore × Stroke)	200ml (68 × 54mm)
Compression ratio	8.5:1
Rated power [kW(Hp)/(r/min)]	4.0/3600
Ignition system	T. C. I
Spark plug	F6RTC
Starting system	Recoil starter, Electric starter
Fuel	Automotive unleaded gasoline
Fuel consumption (g /kW.h)	395
Lube oil	SAE 10W30 (above CC grade)

Fuel tank capacity (L)	13
Continuous running time (hr) (at rated output)	9
Noise level(zero load~ full load) [dB(A)/7m]	62-65 *
Overall dimension (L × W × H) [mm(in)]	IG3000: 686 × 425 × 505(27.01 × 16.73 × 19.88)
Dry weight [kg(lbs)]	IG3000: 60 (132) IGLB3000: 162 (356.4)

*: The declared values shall consider uncertainties due to production variation and measurement procedures.

11. WIRING DIAGRAM

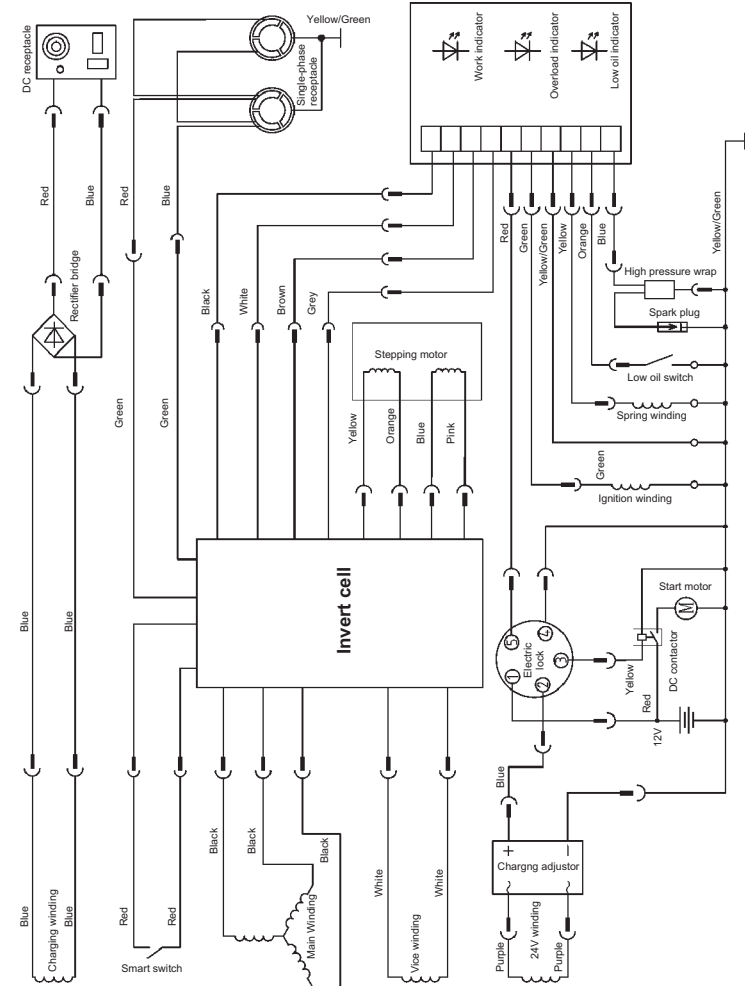
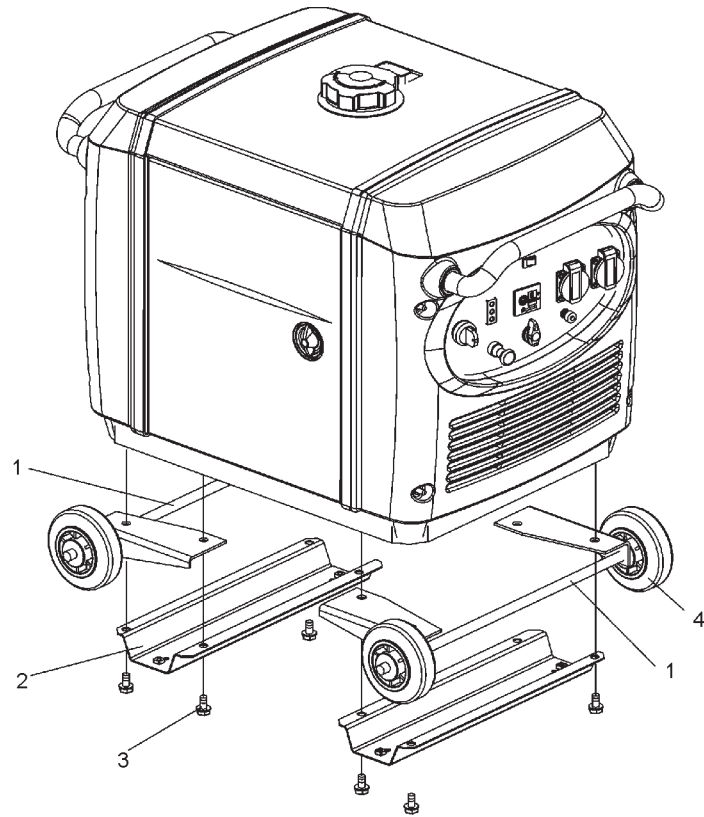

Fig.18 IG3000 Wiring diagram

12. FIXING PICTURE OF CASTER



- 1 Wheel axel
- 2 Chessis setting beam
- 3 Bolt
- 4 Wheel

A. Disassemble the chassis setting beam

- a. Remove the bolt M8X16.
- b. Demount the chassis setting beam.

- 1. Chassis setting beam.
- 2. Bolt

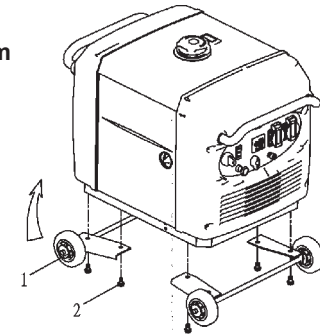

B. Installing the caster wheel parts

- a. Put a big gasket at each caster, and put them on the axle
- b. Fix them with lock pin 12

- 1. land wheel
- 2. axle welding
- 3. lock pin
- 4. big gasket

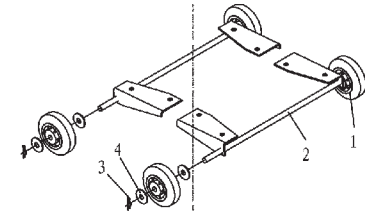

C. Installation of the caster wheel

- a. Align the caster wheel fixing hole with the chassis fixing hole
- b. Tightly lock the caster wheel with M8X16 bolt

- 1. Caster wheel assembly
- 2. Bolt

