

ALPHAGEN™

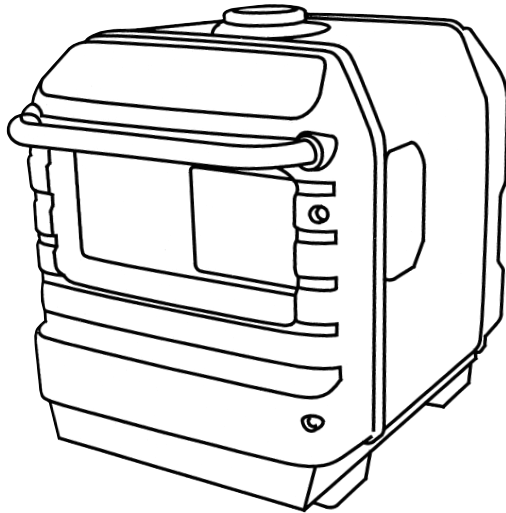

36/48V DC Generator
DCX3000

Owner's Manual



WARNING:



The engine exhaust from this product contains chemicals known to the State of California to cause cancer, birth defects or other reproductive harm.

Keep this owner's manual handy, so you can refer to it at any time. This owner's manual is considered a permanent part of the generator and should remain with the generator if resold.

The information and specifications included in this publication were in effect at the time of approval for printing. Honda Motor Co., Ltd. reserves the right, however, to discontinue or change specifications or design at any time without notice and without incurring any obligation whatever.

INTRODUCTION

Congratulations on your selection of this generator. We are certain you will be pleased with your purchase of one of the finest generators on the market.

We want to help you get the best results from your new generator and to operate it safely. This manual contains all the information on how to do that; please read it carefully.

As you read this manual, you will find information preceded by a **NOTICE** symbol. That information is intended to help you avoid damage to your generator, other property, or the environment.

We suggest you read the warranty policy to fully understand its coverage and your responsibilities of ownership. The warranty policy is a separate document that should have been given to you by your dealer.

When your generator needs scheduled maintenance, keep in mind that your Alphagen servicing dealer is specially trained in servicing this generator. Please contact your Alphagen dealer to have your generator serviced. Your servicing dealer is dedicated to your satisfaction and will be pleased to answer your questions and concerns.

Best Wishes,

A FEW WORDS ABOUT SAFETY

Your safety and the safety of others are very important. And using this generator safely is an important responsibility.

To help you make informed decisions about safety, we have provided operating procedures and other information on labels and in this manual. This information alerts you to potential hazards that could hurt you or others.

Of course, it is not practical or possible to warn you about all the hazards associated with operating or maintaining a generator. You must use your own good judgement.

You will find important safety information in a variety of forms, including:

- **Safety Labels** — on the generator.
- **Safety Messages** — preceded by a safety alert symbol  and one of three signal words, DANGER, WARNING, or CAUTION.

These signal words mean:

 **DANGER**

You WILL be KILLED or SERIOUSLY HURT if you don't follow instructions.

 **WARNING**

You CAN be KILLED or SERIOUSLY HURT if you don't follow instructions.

 **CAUTION**

You CAN be HURT if you don't follow instructions.

- **Safety Headings** — such as *IMPORTANT SAFETY INFORMATION*.
- **Safety Section** — such as *GENERATOR SAFETY*.
- **Instructions** — how to use this generator correctly and safely.

This entire book is filled with important safety information — please read it carefully.

CONTENTS

GENERATOR SAFETY	6
IMPORTANT SAFETY INFORMATION	6
Operator Responsibility.....	6
Carbon Monoxide Hazards.....	6
Electric Shock Hazards	7
Fire and Burn Hazards	7
Refuel With Care	8
SAFETY LABEL LOCATIONS	9
CONTROLS & FEATURES.....	12
COMPONENT & CONTROL LOCATIONS	12
CONTROLS.....	14
DC Voltage Selector Switch	14
Fuel Valve Lever	14
Choke Knob	15
Engine Switch.....	15
Recoil Starter	16
Output Switch.....	16
FEATURES.....	17
Ground Terminal.....	17
DC Output Coupler.....	17
Voltmeter	17
EcoThrottle™ System.....	17
Output Indicator	18
Overload Indicator	18
Oil Alert® Indicator	19
Fuel Gauge.....	19
BEFORE OPERATION	20
ARE YOU READY TO GET STARTED ?.....	20
Knowledge.....	20
IS YOUR GENERATOR READY TO GO ?.....	20
Check the Engine.....	21

CONTENTS

OPERATION	22
SAFE OPERATING PRECAUTIONS	22
STARTING THE ENGINE/DC OPERATION	23
Forced Output.....	26
STOPPING THE ENGINE	28
SERVICING YOUR GENERATOR.....	30
THE IMPORTANCE OF MAINTENANCE	30
MAINTENANCE SAFETY.....	31
Safety Precautions	31
MAINTENANCE SCHEDULE	32
REFUELING	33
FUEL RECOMMENDATIONS	34
ENGINE OIL LEVEL CHECK	35
ENGINE OIL CHANGE.....	36
ENGINE OIL RECOMMENDATIONS.....	37
AIR CLEANER SERVICE	38
FOAM AIR FILTER CLEANING	40
SEDIMENT CUP CLEANING.....	41
SPARK PLUG SERVICE.....	43
SPARK ARRESTER SERVICE.....	45

CONTENTS

STORAGE	48
STORAGE PREPARATION.....	48
Cleaning.....	48
Fuel.....	48
Engine Preparation.....	51
STORAGE PRECAUTIONS.....	52
REMOVAL FROM STORAGE.....	52
TRANSPORTING	53
TAKING CARE OF UNEXPECTED PROBLEMS	54
ENGINE PROBLEMS.....	54
GENERATOR PROBLEMS	56
TECHNICAL & CONSUMER INFORMATION	58
TECHNICAL INFORMATION	58
Serial Number Location	58
Carburetor Modification for High Altitude Operation.....	59
Oxygenated Fuels	60
Emission Control System Information.....	61
Air Index.....	63
Specifications	64
Wiring Diagram.....	65
CONSUMER INFORMATION	66
Publications	66
Customer Service Information.....	67
INDEX	68
QUICK REFERENCE INFORMATION	Inside back cover

GENERATOR SAFETY

IMPORTANT SAFETY INFORMATION

This generator is designed for use with CATV/Telecommunications equipment that has suitable power requirements. Other uses can result in injury to the operator or damage to the generator and other property.

Most accidents can be prevented if you follow all instructions in this manual and on the generator. The most common hazards are discussed below, along with the best way to protect yourself and others.

Operator Responsibility

- Know how to stop the generator quickly in case of emergency.
- Understand the use of all generator controls, output receptacles, and connections.
- Be sure that anyone who operates the generator receives proper instruction. Do not let children operate the generator without parental supervision.

Carbon Monoxide Hazards

- Exhaust contains poisonous carbon monoxide, a colorless, odorless gas. Breathing exhaust can cause loss of consciousness and may lead to death.
- If you run the generator in a confined or even partially enclosed area, the air you breathe could contain dangerous amounts of exhaust gas. To keep exhaust gas from building up, provide adequate ventilation.

Electric Shock Hazards

- The generator produces enough electric power to cause a serious shock or electrocution if misused.
- Do not touch uninsulated portion of output coupler.
Risk of electrical shock.
- Using a generator or electrical appliance in wet conditions, such as rain or snow, or near a pool or sprinkler system, or when your hands are wet, could result in electrocution. Keep the generator dry.
- If the generator is stored outdoors, unprotected from the weather, check all of the electrical components on the control panel, before each use. Moisture or ice can cause a malfunction or short circuit in electrical components which could result in electrocution.

Fire and Burn Hazards

- The exhaust system gets hot enough to ignite some materials.
 - Keep the generator at least 3 feet (1 meter) away from buildings and other equipment during operation.
 - Do not enclose the generator in any structure.
 - Keep flammable materials away from the generator.
- The muffler becomes very hot during operation and remains hot for a while after stopping the engine. Be careful not to touch the muffler while it is hot. Let the engine cool before storing the generator indoors.

GENERATOR SAFETY

Refuel With Care

Gasoline is extremely flammable, and gasoline vapor can explode. Allow the engine to cool if the generator has been in operation. Refuel only outdoors in a well-ventilated area with the engine OFF. Do not overfill the fuel tank. Never smoke near gasoline, and keep other flames and sparks away. Always store gasoline in an approved container. Make sure that any spilled fuel has been wiped up before starting the engine.



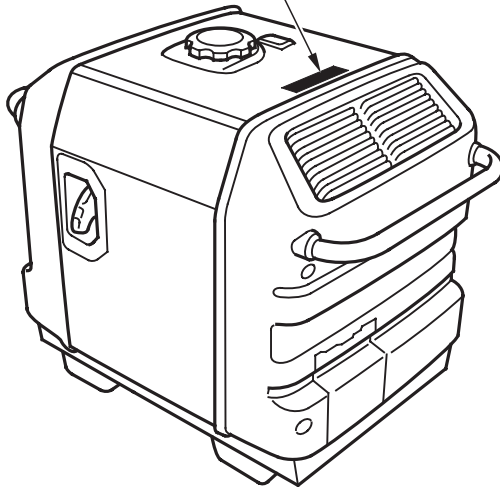
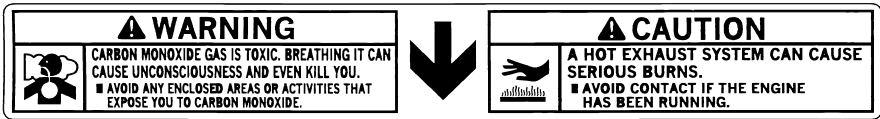

GENERATOR SAFETY

SAFETY LABEL LOCATIONS

These labels warn you of potential hazards that can cause serious injury. Read them carefully. If a label comes off or becomes hard to read, contact your Alphagen servicing dealer for a replacement.



GENERATOR SAFETY

⚠ WARNING	
	<p>GASOLINE IS HIGHLY FLAMMABLE AND EXPLOSIVE. YOU COULD BE BURNED OR SERIOUSLY INJURED IF THE GASOLINE IS IGNITED.</p> <ul style="list-style-type: none">■ BEFORE REFUELING, STOP THE ENGINE AND KEEP HEAT, SPARKS AND FLAME AWAY.■ HANDLE FUEL ONLY OUTDOORS.■ DO NOT FILL THE FUEL TANK ABOVE THE UPPER LIMIT LINE.■ WIPE UP SPILLS IMMEDIATELY.
	<p>EXHAUST CONTAINS POISONOUS CARBON MONOXIDE GAS THAT CAN BUILD UP TO DANGEROUS LEVELS IN CLOSED AREAS. BREATHING CARBON MONOXIDE CAN CAUSE UNCONSCIOUSNESS OR DEATH.</p> <ul style="list-style-type: none">■ NEVER RUN THE GENERATOR IN A CLOSED, OR EVEN PARTLY CLOSED AREA WHERE PEOPLE MAY BE PRESENT.
	<p>THE GENERATOR IS A POTENTIAL SOURCE OF ELECTRICAL SHOCK IF NOT KEPT DRY.</p> <ul style="list-style-type: none">■ DO NOT EXPOSE THE GENERATOR TO MOISTURE, RAIN OR SNOW.■ DO NOT OPERATE THE GENERATOR WITH WET HANDS.
	<p>READ OWNER'S MANUAL CAREFULLY BEFORE OPERATION.</p>

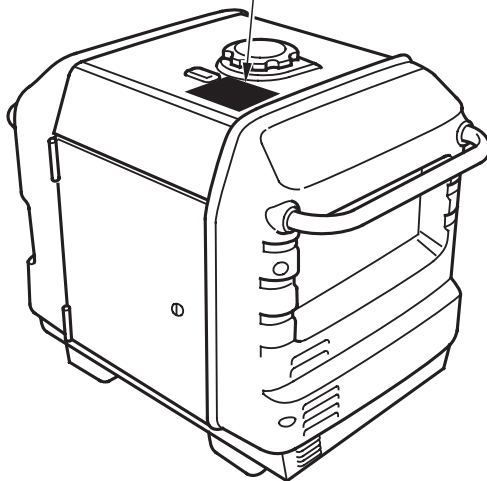

⚠ DANGER	
	RISK OF ELECTRICAL SHOCK. DO NOT TOUCH UNINSULATED PORTION OF OUTPUT COUPLER.

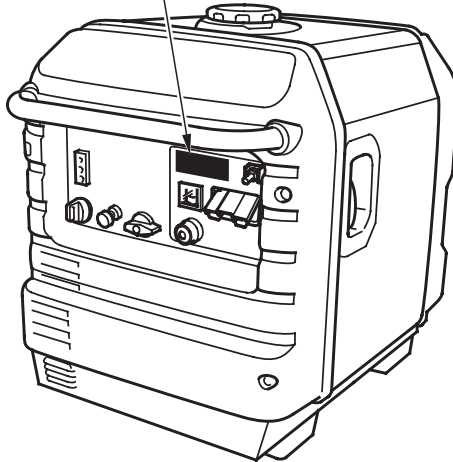

CONTROLS & FEATURES

COMPONENT & CONTROL LOCATIONS

Use the two illustrations on these pages to locate and identify the most frequently used controls.

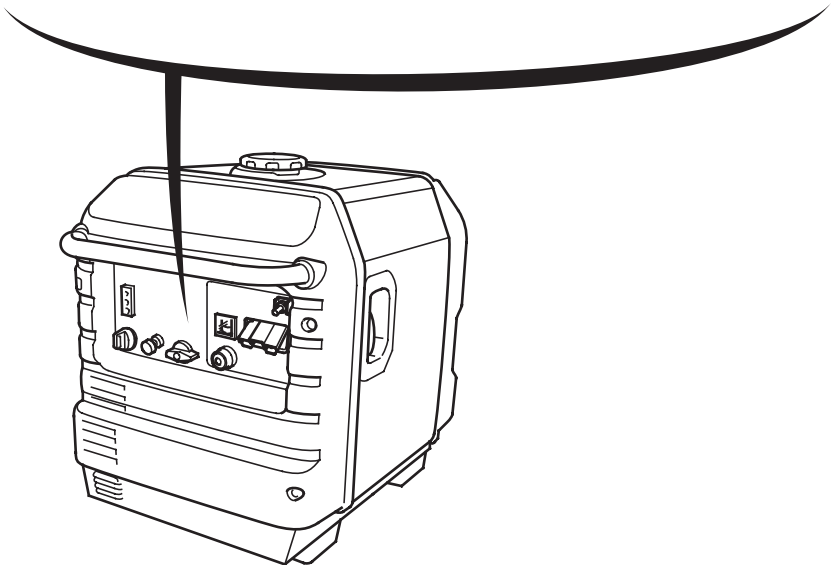
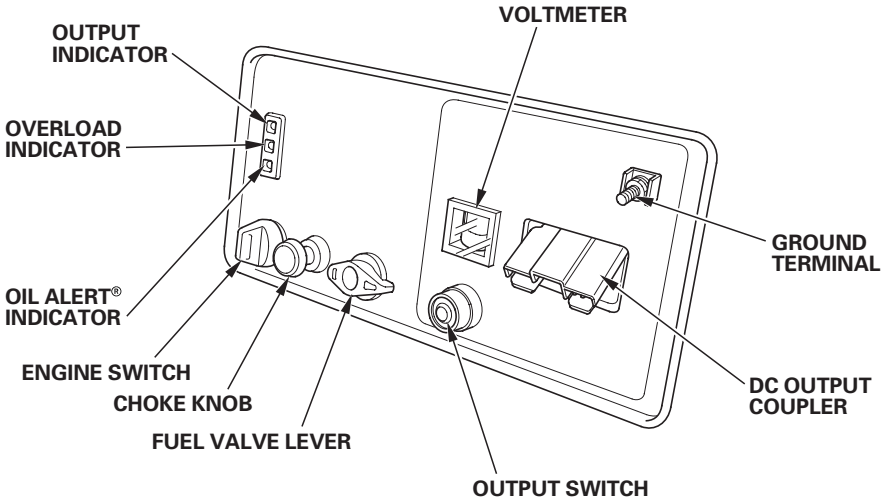

CONTROL & FEATURES

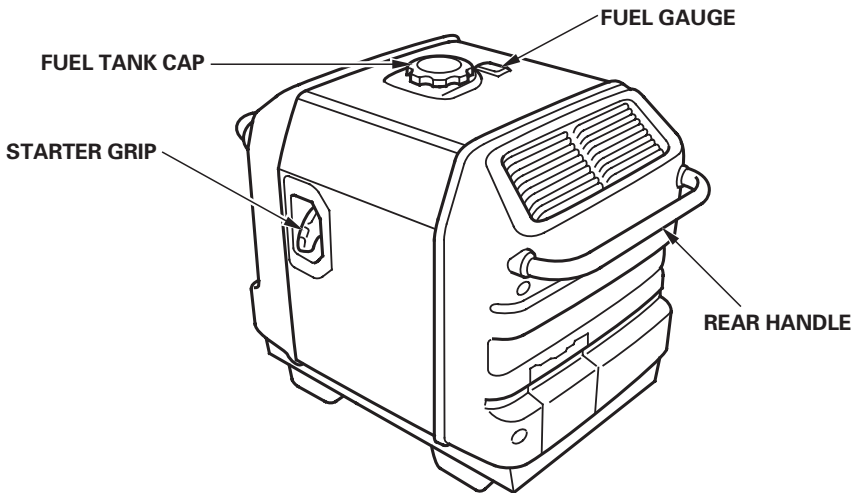
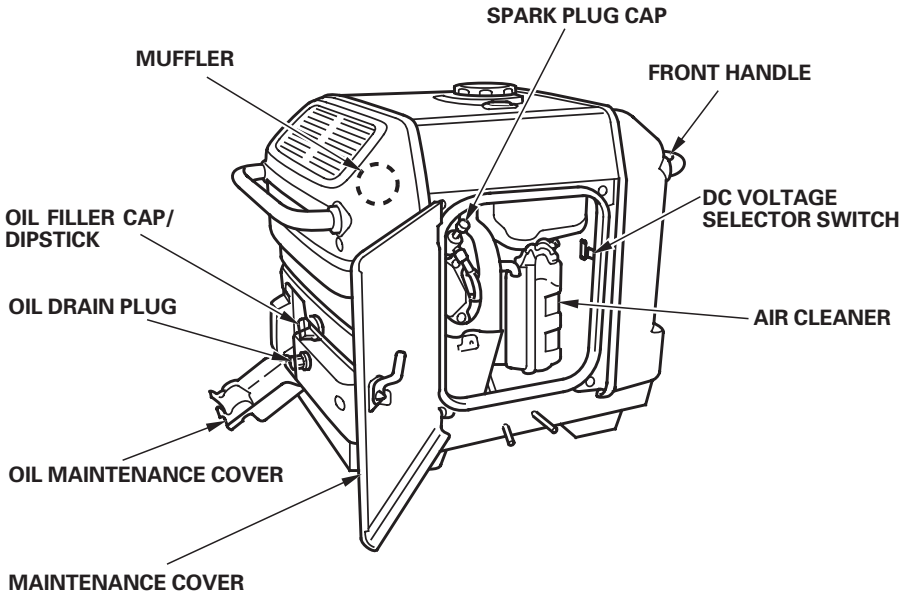

CONTROL & FEATURES

CONTROLS

DC Voltage Selector Switch

The DC voltage selector switch is used to select generator DC voltage; either 36 V or 48 V. Select the same voltage as the battery voltage of the UPS battery string.

To operate the DC voltage selector switch, make sure the engine is off, then open the maintenance cover.

After selecting the voltage, close the maintenance cover.

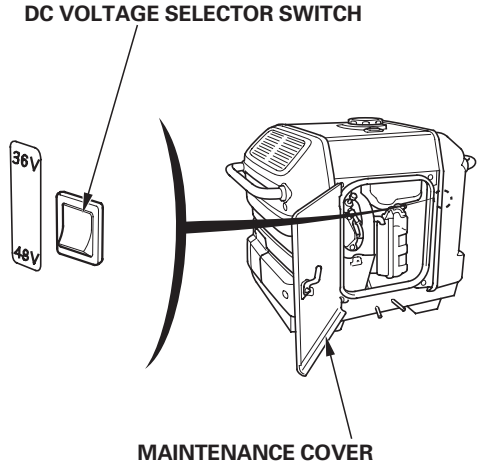

Fuel Valve Lever

The fuel valve lever is located on the control panel.

The fuel valve lever must be in the ON position for the engine to run.

After stopping the engine, turn the fuel valve lever to the OFF position.

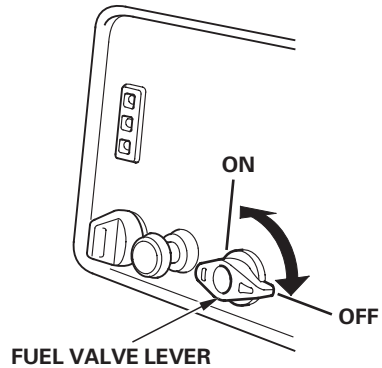

CONTROLS

Choke Knob

The choke knob opens and closes the choke valve in the carburetor.

The **CLOSED** position enriches the fuel mixture for starting a cold engine.

The **OPEN** position provides the correct fuel mixture for operation after starting, and for restarting a warm engine.

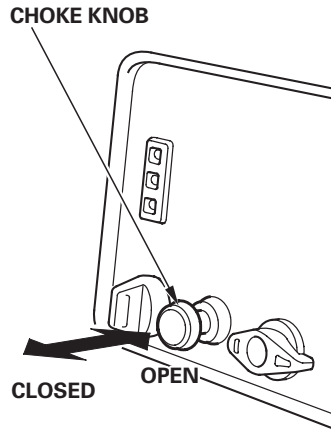

Engine Switch

The engine switch controls the ignition system.

OFF — Stops the engine. The engine switch key can be removed/inserted.

ON — Running position, and for starting with the recoil starter.

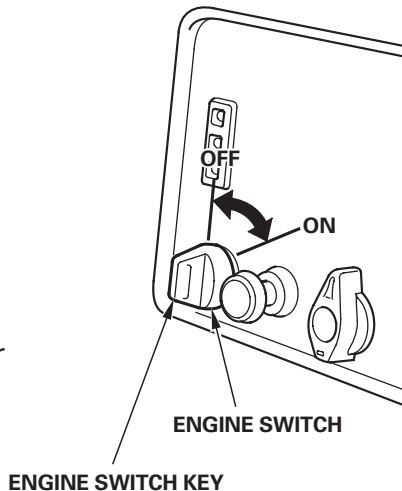

CONTROL & FEATURES

Recoil Starter

Pulling the starter grip operates the recoil starter to crank the engine for starting.

NOTICE

- *Do not allow the starter grip to snap back against the engine. Return it gently to prevent damage to the starter.*
- *Do not let the starter rope rub against the generator body or the rope will wear out prematurely.*

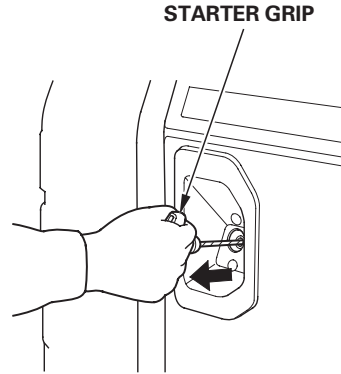

Output Switch

The output switch has two functions.

- **Stop Output**
During the output operation, press the output switch to stop output. To reset, stop and restart the engine.
- **Forced Output**
Following the forced output procedure, the generator will provide output to charge the battery string when the battery string charge is too low to activate automatic charging.

OUTPUT SWITCH

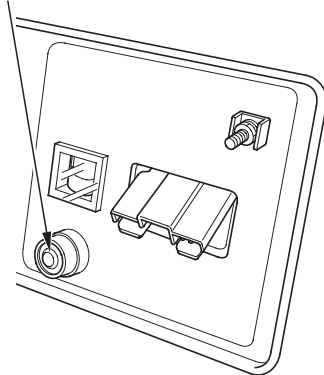

FEATURES

Ground Terminal

The ground terminal is connected to the frame of the generator and the metal non-current-carrying parts of the generator.

Before using the ground terminal, consult a qualified electrician, electrical inspector or local agency having jurisdiction for local codes or ordinances that apply to the intended use of the generator.

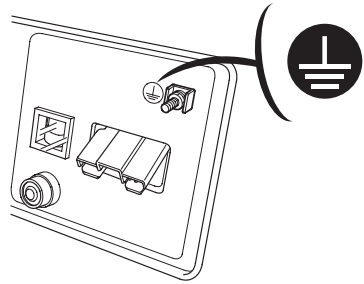

DC Output Coupler

The DC output coupler may ONLY be used for charging UPS 36 V or 48 V battery strings.

When connecting the power cord to the DC output coupler, always use the correct coupler and power cord.

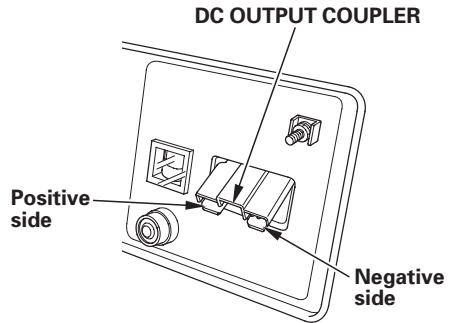

Voltmeter

The voltmeter indicates the voltage of the UPS batteries when connected to the DC output coupler.

EcoThrottle™ System

The EcoThrottle™ system automatically reduces engine speed when the UPS battery string is fully charged.

When the UPS battery string becomes discharged, the engine returns to the proper speed to recharge the batteries.

CONTROL & FEATURES

Output Indicator

The output indicator (green) is illuminated when the generator is operating normally. It indicates that the generator is producing electrical power at the DC output coupler.

OUTPUT INDICATOR
(GREEN)

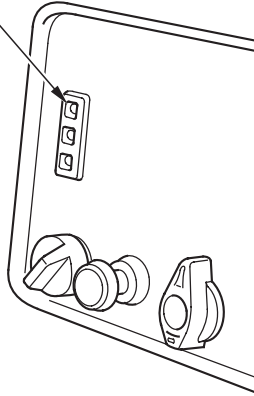

Overload Indicator

The overload indicator (red) will go steady ON if the generator is overloaded, the converter becomes overheated or there is a short circuit in the connected UPS battery string. The overload indicator (red) will stay ON, and after about five seconds, current to the connected UPS and the output indicator (green) will go OFF. When the UPS battery voltage is too low or too high, the overload indicator (red) will flash.

OVERLOAD INDICATOR
(RED)

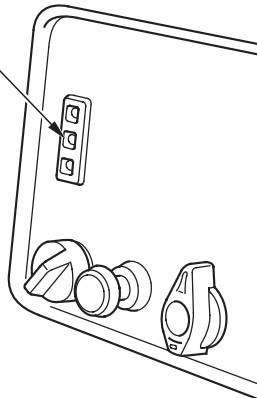

Oil Alert® Indicator

The Oil Alert® system is designed to prevent engine damage caused by an insufficient amount of oil in the crankcase. Before the oil level in the crankcase can fall below a safe limit, the Oil Alert® indicator comes on and the Oil Alert® system automatically will stop the engine (the engine switch will remain in the ON position).

If the engine stops or the Oil Alert® indicator comes on when you pull the starter grip, check the engine oil level (see page 35) before troubleshooting in other areas.

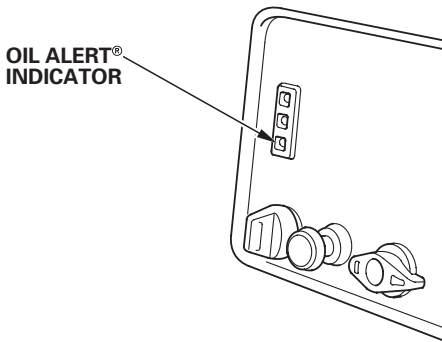

Fuel Gauge

The fuel gauge is a mechanical device that measures the fuel level in the tank. The red indicator in the window will reference the level in relation to full or empty. To provide increased operating time, start with a full tank before beginning operation. Check the fuel level with the generator on a level surface. Always refuel with the engine OFF and cool.

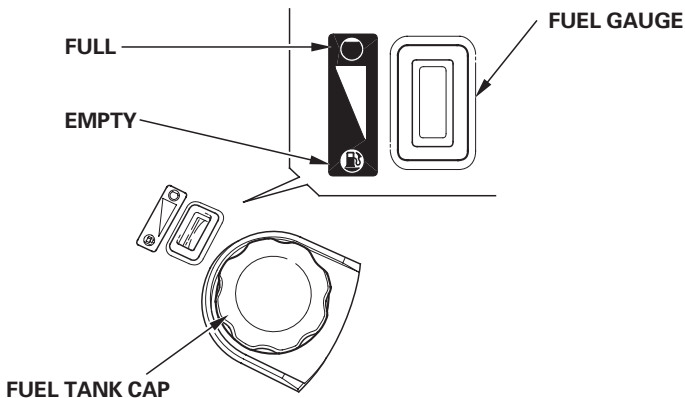

BEFORE OPERATION

ARE YOU READY TO GET STARTED?

Your safety is your responsibility. A little time spent in preparation will significantly reduce your risk of injury.

Knowledge

Read and understand this manual. Know what the controls do and how to operate them.

Familiarize yourself with the generator and its operation before you begin using it. Know how to quickly shut off the generator in case of an emergency.

When the generator is being used, check the voltage requirement of the UPS battery strings. This generator is designed to charge 36 V and 48 V battery strings.

IS YOUR GENERATOR READY TO GO?

For your safety, and to maximize the service life of your equipment, it is very important to take a few moments before you operate the generator to check its condition. Be sure to take care of any problem you find, or have your servicing dealer correct it, before you operate the generator.

⚠ WARNING

Improperly maintaining this generator, or failing to correct a problem before operation, could cause a malfunction in which you could be seriously injured.

Always perform a preoperation inspection before each operation, and correct any problem.

To prevent a possible fire, keep the generator at least 3 feet (1 meter) away from building walls and other equipment during operation. Do not place flammable objects close to the engine.

Before beginning your preoperation checks, be sure the generator is on a level surface and the engine switch is in the OFF position.

Check the Engine

Check the oil level (see page 35). A low oil level will cause the Oil Alert® system to shut down the engine.

Check the air filter (see page 38). A dirty air filter will restrict air flow to the carburetor, reducing engine and generator performance.

Check the fuel level (see page 33). Starting with a full tank will help to eliminate or reduce operating interruptions for refueling.

OPERATION

SAFE OPERATING PRECAUTIONS

Before operating the generator for the first time, please review the *GENERATOR SAFETY* section and the chapter titled *BEFORE OPERATION*.

For your safety, avoid starting or operating the generator in an enclosed area such as a garage. Your generator's exhaust contains poisonous carbon monoxide gas which can collect rapidly in an enclosed area and cause illness or death.

WARNING

Carbon monoxide gas is toxic. Breathing it can cause unconsciousness and even kill you.

Avoid any enclosed areas or activities that expose you to carbon monoxide.

Before connecting power cord to the generator:

- This generator is a DC only generator which connects to the UPS and is made to charge the UPS battery strings. When connecting the power cord to the DC output coupler always use the correct coupler and power cord.
- Mark sure the positive terminal of the UPS battery string is connected to generator positive side of DC output coupler.
- Inspect power cord and coupler, and replace if damaged. Faulty power cords and coupler can create a potential for electric shock.
- Operate the generator at least 3 feet (1 meter) away from buildings and other equipment.
- Do not operate the generator in an enclosed structure.

STARTING THE ENGINE/DC OPERATION

1. Select the same voltage as the battery voltage of UPS.
 - a. Open the maintenance cover.
 - b. Select the DC voltage selector switch; either 36 V or 48 V.
 - c. Close the maintenance cover.

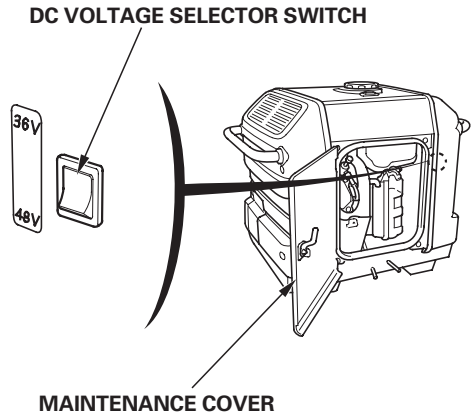

2. Connect the power cord of UPS to the DC output coupler.

When the UPS battery string is connected to the generator, the back light in the voltmeter is turned on and indicates the battery string voltage.

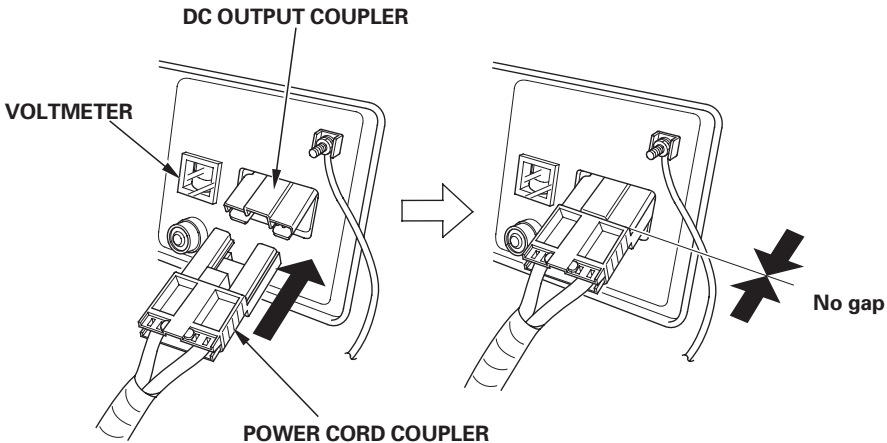

OPERATION

3. Turn the fuel valve lever to the ON position.

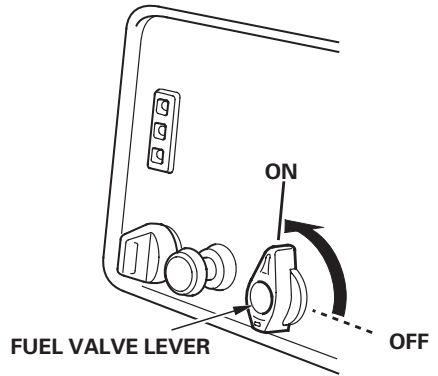

4. Pull the choke knob to the CLOSED position to start a cold engine.

Leave the choke knob in the OPEN position to restart a warm engine.

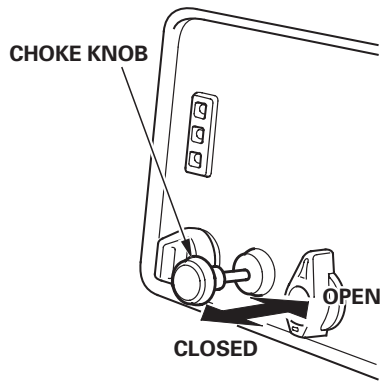

- Turn the engine switch to the ON position.

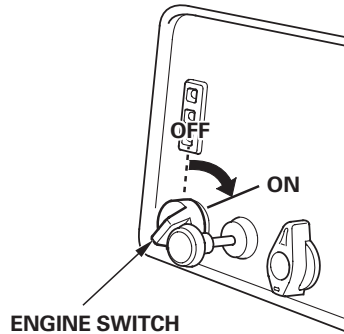

- Pull the starter grip lightly until you feel resistance, then pull briskly. Pull the starter grip as shown in the picture at the right.

NOTICE

- Do not allow the starter grip to snap back against the engine. Return it gently to prevent damage to the starter.
- Do not let the starter rope rub against the generator body or the rope will wear out prematurely.

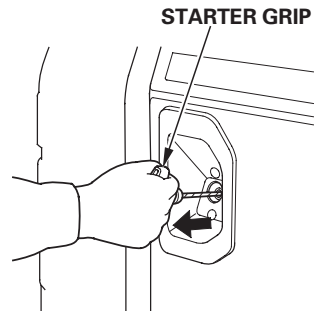

- If the choke knob was pulled to the CLOSED position to start the engine, gradually move it to the OPEN position as the engine warms up.

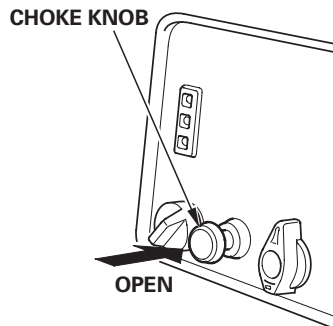

When the engine starts, DC output will begin charging the UPS battery string automatically and the output indicator (green) will go ON. If the UPS battery string voltage is too low, the DC output will be turned off. At this time, the output indicator (green) will go OFF and the overload indicator (red) will go ON. See Forced Output, page 26 for additional information.

OPERATION

Forced Output

The forced output function should only be used by personnel who are knowledgeable regarding UPS battery string operation. Follow the instructions in the UPS battery owner's manual.

The DC voltage selector switch must be set equal to the voltage of the UPS battery string. Incorrectly setting the voltage selector switch may cause damage or fire to the UPS battery string. The engine must be stopped whenever you change the DC voltage selector switch.

Forced output can only be initiated if the DC output does not initiate automatically when following the "STARTING THE ENGINE/DC OPERATION" procedure (see pages 23 – 25).

In addition, the forced output function is dependant on the UPS battery voltage string voltage. Forced output can only be initiated if the conditions shown in the following table are met.

Applicable conditions:

Output voltage depends on the DC voltage selector switch position. Forced output is allowed under the following conditions.

DC Voltage Selector switch	UPS battery Voltage	Output indicator (Green)	Overload indicator (red)
36 V	2 – 27 V	OFF	FLASH
48 V	2 – 42 V	OFF	FLASH

Operation:

1. Verify that the overload indicator (red) is flashing.
2. Press the output switch for 5 seconds, the overload indicator (red) will go off.
Release your finger from the switch.
If step 3 is not carried out within 5 seconds, the overload indicator (red) will start to flash again.
3. Press the output switch for 5 seconds once again.
The output indicator (green) will go ON and forced output starts to work.

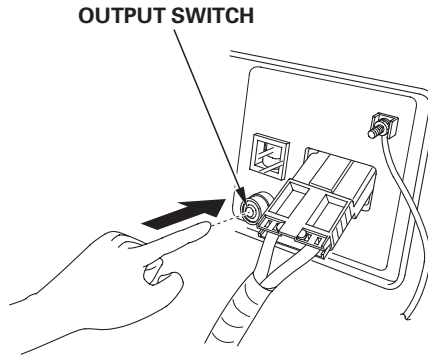

You cannot use forced output with protection function after using the stop output function in normal operation. Stop and restart the engine to reset the generator.

OPERATION

STOPPING THE ENGINE

To stop the engine in an emergency, simply turn the engine switch to the OFF position. Under normal conditions, use the following procedure.

1. Push the output switch.

Output is off, but engine is operating.

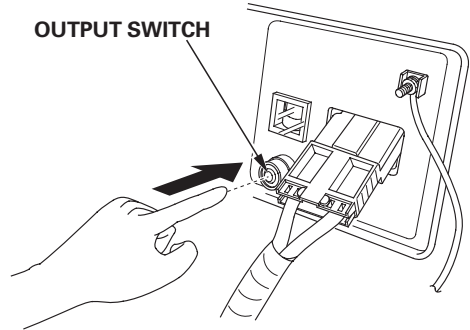

2. Turn the engine switch to the OFF position.

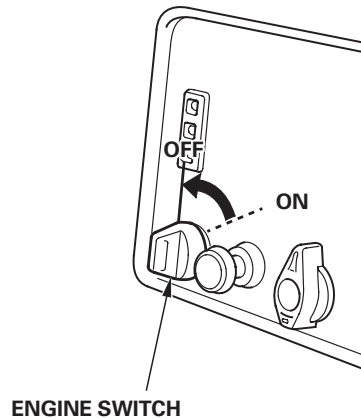

3. Turn the fuel valve lever to the OFF position.

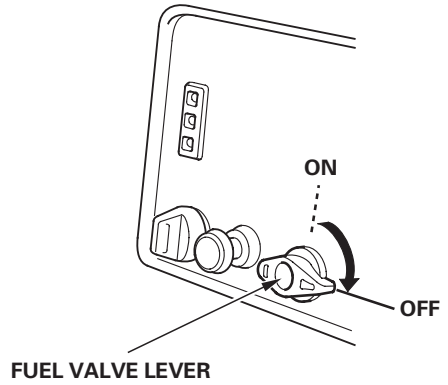

4. Remove the power cord coupler from the DC output coupler.

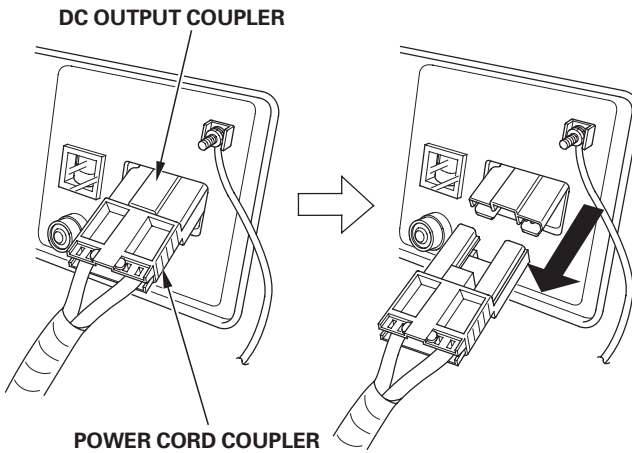

SERVICING YOUR GENERATOR

THE IMPORTANCE OF MAINTENANCE

Good maintenance is essential for safe, economical, and trouble-free operation. It will also help reduce air pollution.

To help you properly care for your generator, the following pages include a maintenance schedule, routine inspection procedures, and simple maintenance procedures using basic hand tools. Other service tasks that are more difficult, or require special tools, are best handled by professionals and are normally performed by an Alphagen technician or other qualified mechanic.

The maintenance schedule applies to normal operating conditions. If you operate your generator under unusual conditions, such as sustained high-load or high-temperature operation, or use it in dusty conditions, consult your servicing dealer for recommendations applicable to your individual needs and use.

WARNING

Improper maintenance, or failure to correct a problem before operation, can cause a malfunction in which you can be seriously hurt or killed.

Always follow the inspection and maintenance recommendations and schedules in this owner's manual.

Remember that your servicing dealer knows your generator best and is fully equipped to maintain and repair it.

To ensure the best quality and reliability, use only new, genuine Honda parts or their equivalents for repair and replacement.

Maintenance, replacement, or repair of the emission control devices and systems may be performed by any engine repair establishment or individual, using parts that are "certified" to EPA standards.

MAINTENANCE SAFETY

Some of the most important safety precautions follow. However, we cannot warn you of every conceivable hazard that can arise in performing maintenance. Only you can decide whether or not you should perform a given task.

WARNING

Failure to properly follow maintenance instructions and precautions can cause you to be seriously hurt or killed.

Always follow the procedures and precautions in the owner's manual.

Safety Precautions

Make sure the engine is off before you begin any maintenance or repairs. This will eliminate several potential hazards:

- **Carbon monoxide poisoning from engine exhaust.**
Be sure there is adequate ventilation whenever you operate the engine.
- **Burns from hot parts.**
Let the engine and exhaust system cool before touching.
- **Injury from moving parts.**
Do not run the engine unless instructed to do so.
- Read the instructions before you begin, and make sure you have the tools and skills required.
- To reduce the possibility of fire or explosion, be careful when working around gasoline. Use only a nonflammable solvent, not gasoline, to clean parts. Keep cigarettes, sparks, and flames away from all fuel-related parts.

SERVICING YOUR GENERATOR

MAINTENANCE SCHEDULE

REGULAR SERVICE PERIOD (3)		Each use	First month or 20 Hrs.	Every 3 months or 50 Hrs.	Every 6 months or 100 Hrs.	Every year or 300 Hrs.	Page
ITEM	Perform at every indicated month or operating hour interval, whichever comes first.						
Engine oil	Check level	○					35
	Change		○		○		36
Air filter	Check	○					38
	Clean			○ (1)			40
	Replace					○ *	38
Sediment cup	Clean				○		41
Spark plug	Check-adjust				○		43
	Replace					○	
Spark arrester	Clean				○		45
Valve clearance	Check-adjust					○ (2)	—
Combustion chamber	Clean	After every 500 Hrs. (2)					—
Fuel tank and filter	Clean					○ (2)	—
Fuel line	Check	Every 2 years (Replace if necessary) (2)					—

* Replace the paper air filter element only.

(1) Service more frequently when used in dusty areas.

(2) These items should be serviced by an authorized Alphagen generator dealer, unless the owner has the proper tools and is mechanically proficient. See the Shop Manual.

(3) For commercial use, log hours of operation to determine proper maintenance intervals.

SERVICING YOUR GENERATOR

REFUELING

With the engine stopped, check the fuel level. Refill the tank if the fuel level is low.

⚠ WARNING

Gasoline is highly flammable and explosive.

You can be burned or seriously injured when handling fuel.

- Stop the engine and keep heat, sparks, and flame away.
- Handle fuel only outdoors.
- Wipe up spills immediately.

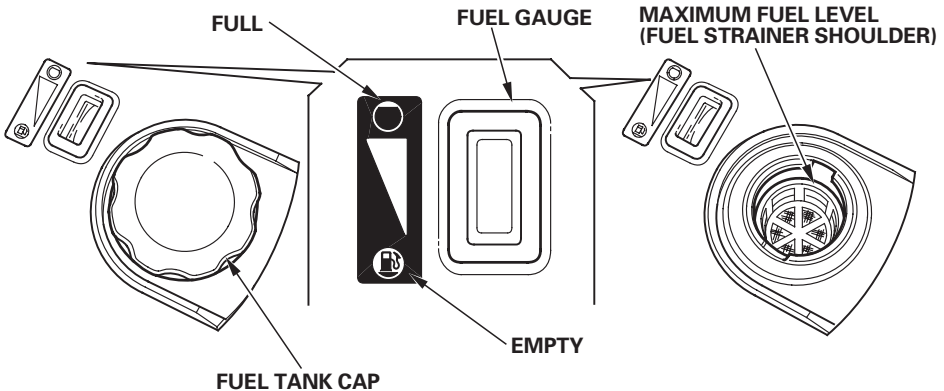

Refuel in a well-ventilated area before starting the engine. If the engine has been running, allow it to cool. Refuel carefully to avoid spilling fuel. Do not fill the fuel tank above the fuel strainer shoulder.

Never refuel the engine inside a building where gasoline fumes may reach flames or sparks. Keep gasoline away from appliance pilot lights, barbecues, electric appliances, power tools, etc. Spilled fuel is not only a fire hazard, it causes environmental damage. Wipe up spills immediately.

SERVICING YOUR GENERATOR

FUEL RECOMMENDATIONS

Use unleaded gasoline with a pump octane rating of 86 or higher.

This engine is certified to operate on unleaded gasoline. Unleaded gasoline produces fewer engine and spark plug deposits and extends exhaust system life.

Never use stale or contaminated gasoline or an oil/gasoline mixture. Avoid getting dirt or water in the fuel tank.

Occasionally you may hear light “spark knock” or “pinging” (metallic rapping noise) while operating under heavy loads. This is no cause for concern.

If spark knock or pinging occurs at a steady engine speed, under normal load, change brands of gasoline. If spark knock or pinging persists, see an Alphagen servicing dealer.

NOTICE

Running the engine with persistent spark knock or pinging can cause engine damage.

Running the engine with persistent spark knock or pinging is misuse, and the *Distributor's Limited Warranty* does not cover parts damaged by misuse.

SERVICING YOUR GENERATOR

ENGINE OIL LEVEL CHECK

Check the engine oil level with the generator on a level surface and the engine stopped.

1. Open the oil maintenance cover.
2. Remove the oil filler cap/dipstick and wipe it clean.
3. Insert and remove the dipstick without screwing it into the filler neck. Check the oil level shown on the dipstick.
4. If the oil level is low, fill to the top of the oil filler neck with the recommended oil (see page 37).
5. Screw in the oil filler cap/dipstick securely.
6. Close and latch the oil maintenance cover.

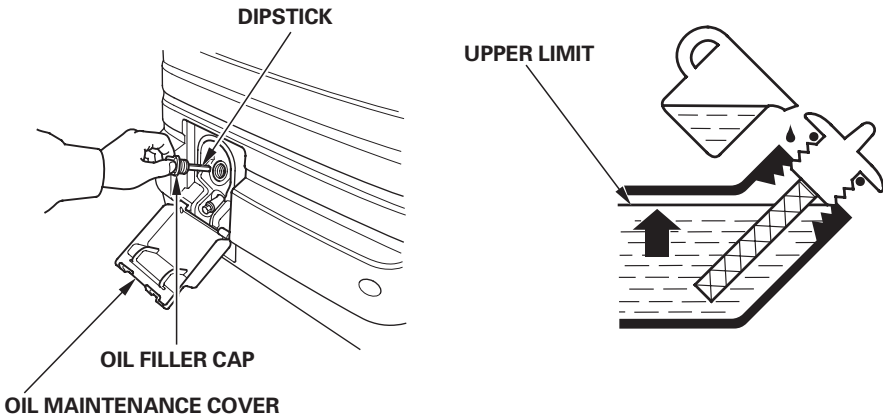

The Oil Alert® system will automatically stop the engine before the oil level falls below safe limits. However, to avoid the inconvenience of an unexpected shutdown, check the oil level regularly.

SERVICING YOUR GENERATOR

ENGINE OIL CHANGE

Drain the oil while the engine is warm to assure rapid and complete draining.

1. Open and remove the oil maintenance cover.
2. Place a suitable container below the engine to catch the used oil, then remove the oil filler cap/dipstick, drain plug and sealing washer.
3. Allow the used oil to drain completely, then reinstall the drain plug and sealing washer. Tighten the plug securely.

NOTICE

Improper disposal of engine oil can be harmful to the environment. If you change your own oil, please dispose of the used oil properly. Put it in a sealed container and take it to a recycling center. Do not discard it in a trash bin, dump it on the ground or pour it down the drain.

4. With the generator in a level position, fill to the outer edge of the oil filter hole with the recommended oil (see page 37).
5. Screw in the oil filler cap/dipstick securely.
6. Reinstall, close and latch the oil maintenance cover.

Wash your hands with soap and water after handling used oil.

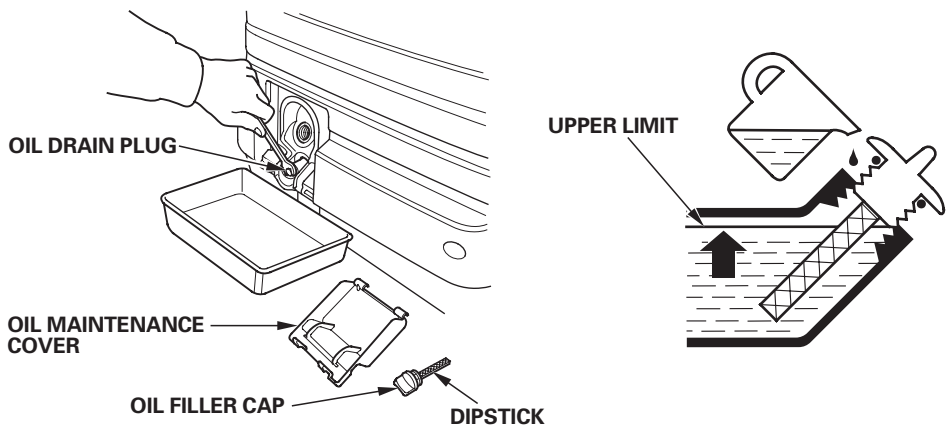

SERVICING YOUR GENERATOR

ENGINE OIL RECOMMENDATIONS

Oil is a major factor affecting performance and service life. Use 4-stroke automotive detergent oil.

SAE 10W–30 is recommended for general use. Other viscosities shown in the chart may be used when the average temperature in your area is within the recommended range.

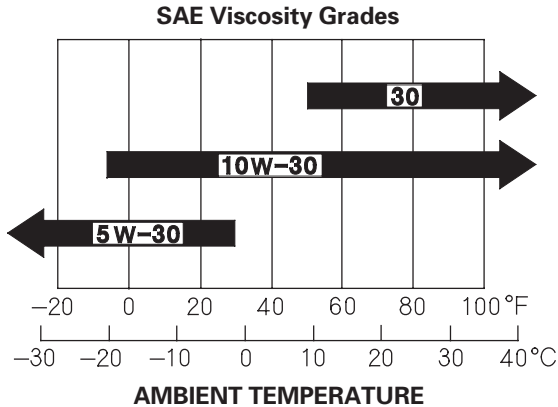

The SAE oil viscosity and service classification are in the API label on the oil container. We recommend that you use API SERVICE category SJ oil.

SERVICING YOUR GENERATOR

AIR CLEANER SERVICE

1. Open the maintenance cover.

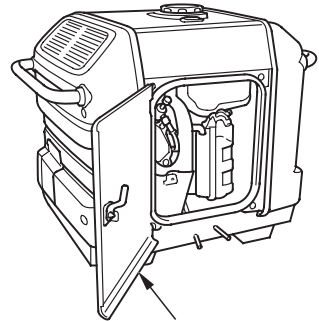

2. Unsnap the air cleaner cover clips, remove the air cleaner cover.

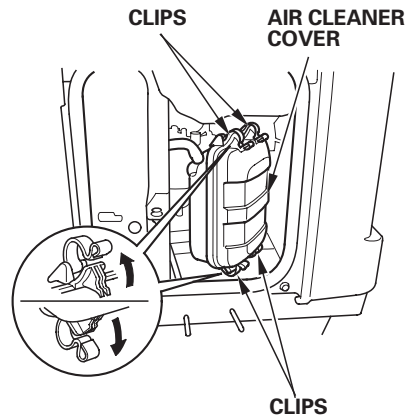

3. Foam air filter:

a. Remove the foam air filter from the air cleaner cover.

b. Check the foam air filter to be sure it is clean and in good condition. If the foam air filter is dirty, clean it as described on page 40. Replace the foam air filter if it is damaged.

c. Reinstall the foam air filter in the air cleaner cover.

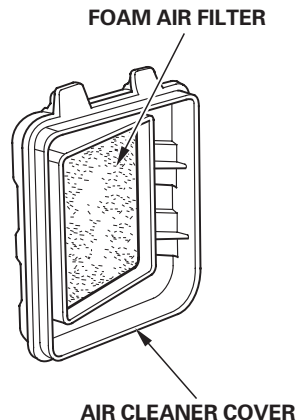

SERVICING YOUR GENERATOR

4. Paper air filter:

If the paper air filter is dirty, replace it with a new one. Do not clean the paper air filter.

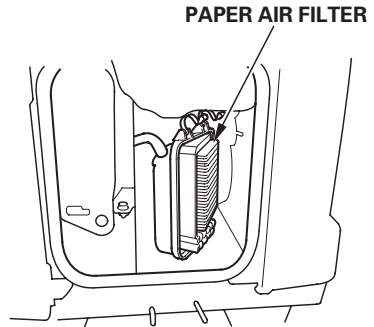

5. Reinstall the air cleaner cover.

6. Close and latch the maintenance cover.

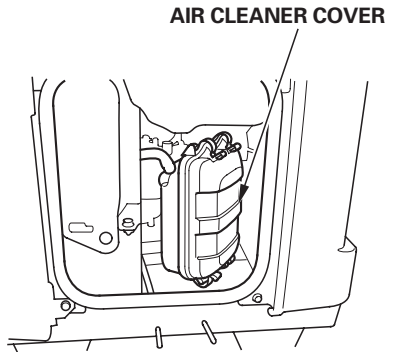

NOTICE

Operating the engine without an air filter, or with a damaged air filter, will allow dirt to enter the engine, causing rapid engine wear. This type of damage is not covered by the Distributor's Limited Warranty.

SERVICING YOUR GENERATOR

FOAM AIR FILTER CLEANING

A dirty foam air filter will restrict air flow to the carburetor, reducing engine performance. If you operate the generator in very dusty areas, clean the foam air filter more frequently than specified in the Maintenance Schedule.

1. Clean the foam air filter in warm soapy water, rinse, and allow to dry thoroughly, or clean in nonflammable solvent and allow to dry.
2. Dip the foam air filter in clean engine oil, then squeeze out all excess oil. The engine will smoke when started if too much oil is left in the filter.

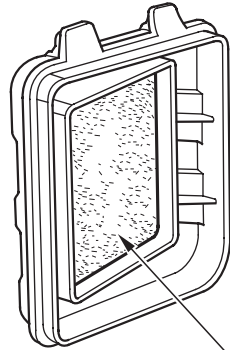

FOAM AIR FILTER

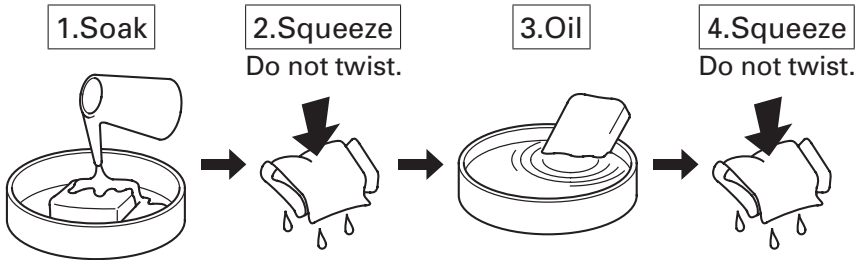

3. Wipe dirt from the air cleaner housing and cover using a moist rag. Be careful to prevent dirt from entering the air duct that leads to the carburetor.

SERVICING YOUR GENERATOR

SEDIMENT CUP CLEANING

1. Turn the fuel valve lever to the OFF position.
2. Open the maintenance cover.
3. Remove the air cleaner cover, foam and paper air filter (see page 38).
4. Disconnect the breather hose from the air cleaner base.
5. Remove the 6 mm bolt and two 6 mm nuts, and remove the air cleaner base.

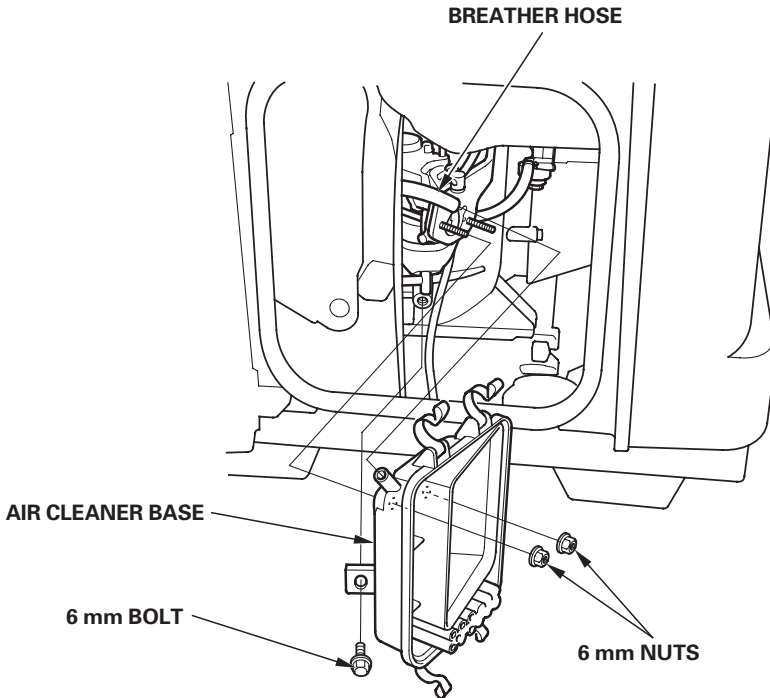

SERVICING YOUR GENERATOR

6. Remove the sediment cup by turning it counterclockwise.

⚠ WARNING

Gasoline is highly flammable and explosive.

You can be burned or seriously injured when handling fuel.

- Stop the engine and keep heat, sparks, and flame away.
- Handle fuel only outdoors.
- Wipe up spills immediately.

7. Wash the sediment cup, O-ring and filter in nonflammable solvent, and dry them thoroughly.

8. Reinstall the filter, new O-ring, and sediment cup.

9. Reinstall the air cleaner base, and connect the breather hose with the air cleaner base.

10. Reinstall the paper air filter and air cleaner cover.

11. Close and latch the maintenance cover.

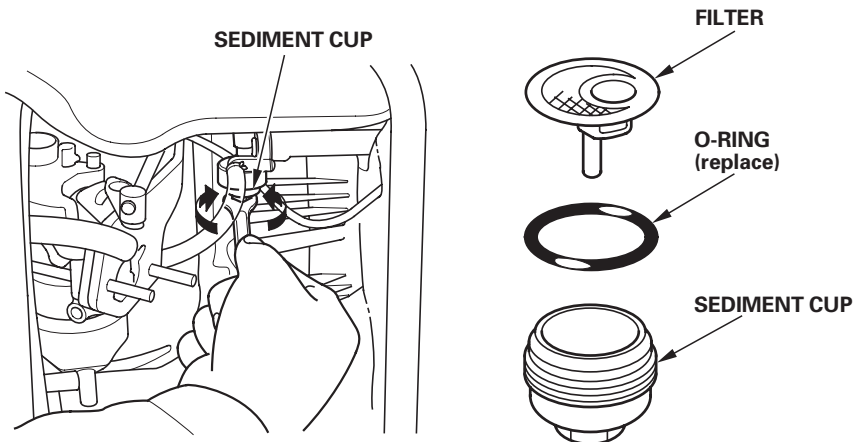

SERVICING YOUR GENERATOR

SPARK PLUG SERVICE

Recommended spark plugs: BPR5ES (NGK)
W16EPR-U (DENSO)

NOTICE

Incorrect spark plugs can cause engine damage.

1. Open the maintenance cover.
2. Loosen the cover screw and remove the spark plug inspection cover.

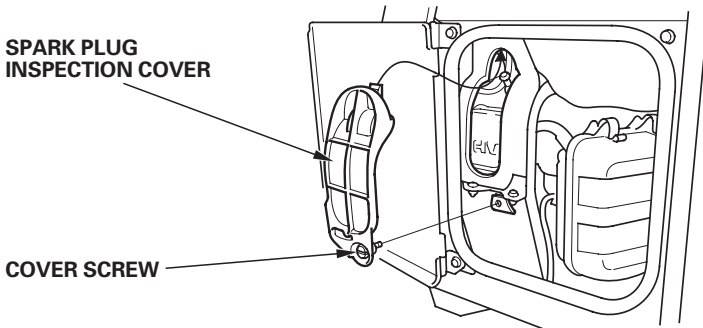

3. Disconnect the spark plug cap, and remove any dirt from around the spark plug area.
4. Remove the spark plug with a 13/16-inch spark plug wrench (commercially available).

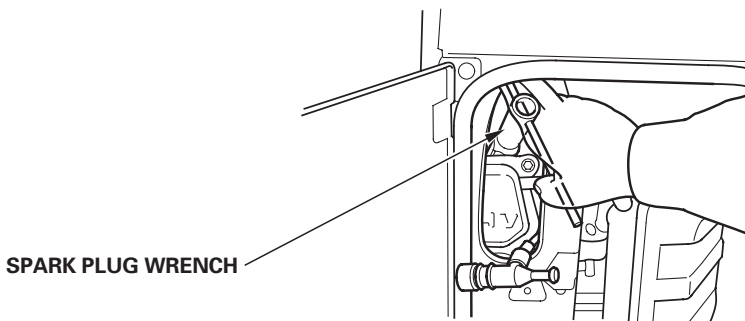

SERVICING YOUR GENERATOR

5. Inspect the spark plug. Replace it if the electrodes are worn or if the insulator is cracked, chipped or fouled.

6. Measure the spark plug electrode gap with a wire-type feeler gauge. Correct the gap, if necessary, by carefully bending the side electrode.

The gap should be:
0.028–0.031 in (0.70–0.80 mm)



7. Make sure that the spark plug sealing washer is in good condition, and thread the spark plug in by hand prevent cross-threading.

8. After the spark plug seats, tighten with a 13/16-inch spark plug wrench to compress the washer.

If reinstalling a used spark plug, tighten 1/8 – 1/4 turn after the spark plug seats.

If installing a new spark plug, tighten 1/2 turn after the spark plug seats.

NOTICE

A loose spark plug can overheat and damage the engine. Overtightening the spark plug can damage the threads in the cylinder head.

9. Attach the spark plug cap.

10. Reinstall the spark plug inspection cover and tighten the cover screw.

11. Close and latch the maintenance cover.

SERVICING YOUR GENERATOR

SPARK ARRESTER SERVICE

The spark arrester must be serviced every 100 hours to keep it functioning as designed.

If the engine has been running, the muffler will be very hot. Allow the muffler to cool before servicing the spark arrester.

1. Remove the four 6 mm cap nuts, and remove the rear cover.
2. Remove the four 6 mm bolts, and remove the upper muffler protector.

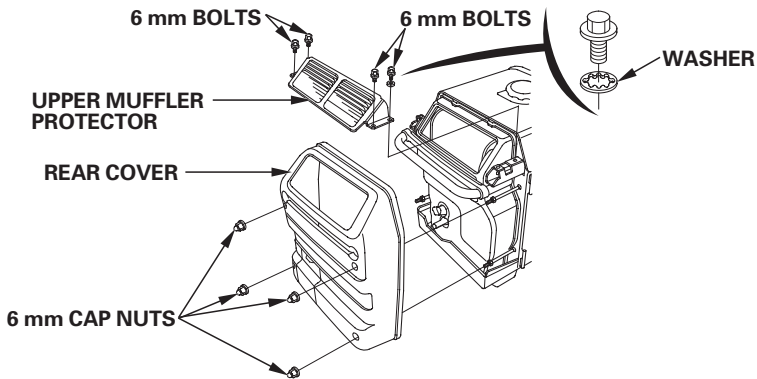

3. Remove the four 8 mm bolts, and remove the rear handle.
4. Remove the four 6 mm bolts, and remove the rear under plate.
5. Remove the lower muffler protector.

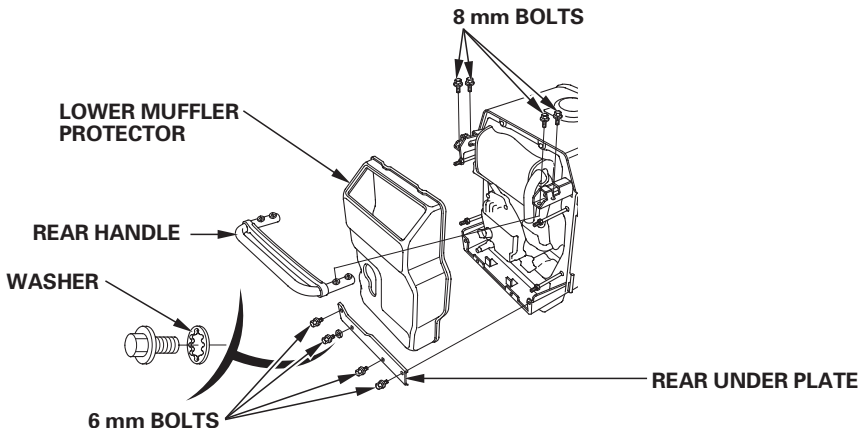

SERVICING YOUR GENERATOR

6. Remove the three 5 mm bolts, and remove the exhaust tail pipe and the spark arrester.

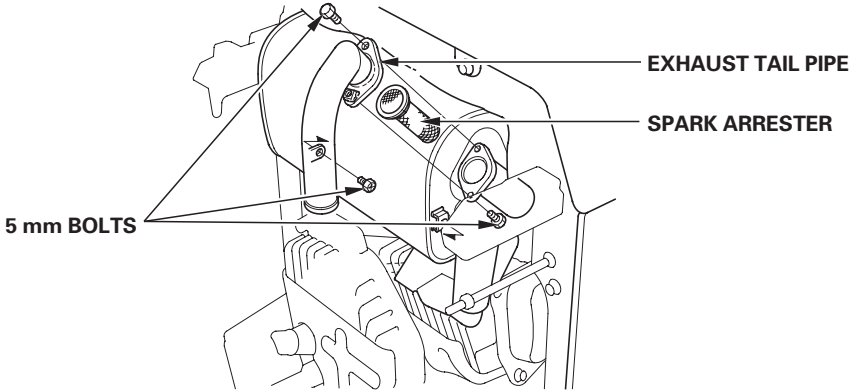

7. Use a brush to remove carbon deposits from the spark arrester screen.
Be careful to avoid damaging the screen.

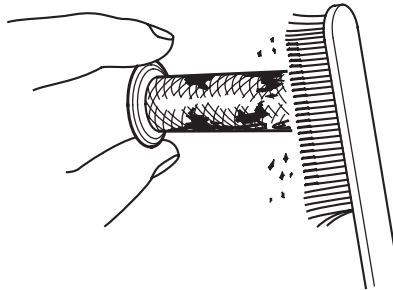

8. Inspect the spark arrester screen for breaks, holes or tears. Replace it if necessary.
9. Install the spark arrester and the exhaust tail pipe in the reverse order of removal.

SERVICING YOUR GENERATOR

10. Install the lower muffler protector, the rear under plate and the rear handle in the reverse order of removal.
Install the lower muffler protector inside the hook securely.

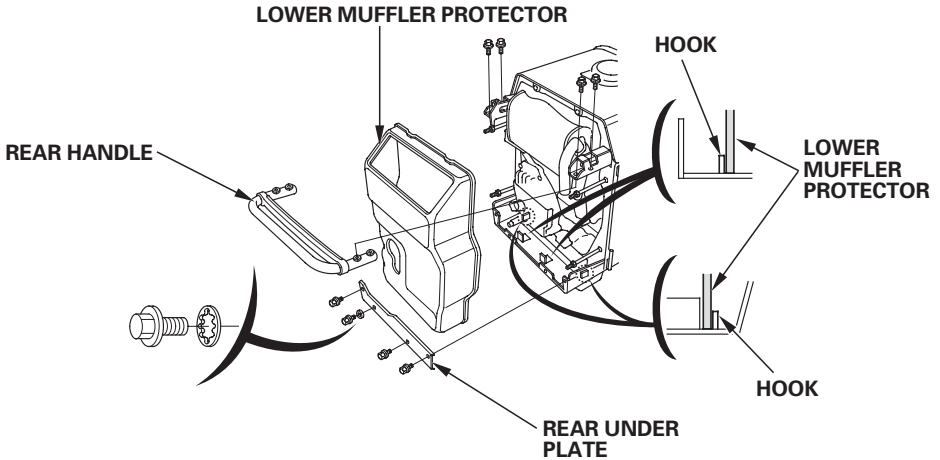

11. Install the upper muffler protector and the rear cover in the reverse order of removal.
When installing the rear cover, carefully fit the rubber drip guard around the oil filler neck and oil drain neck.

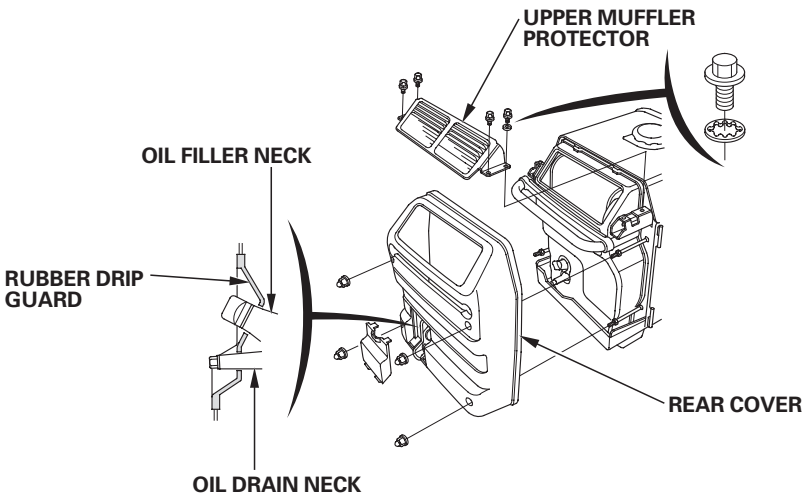

STORAGE

STORAGE PREPARATION

Proper storage preparation is essential for keeping your generator trouble-free and looking good. The following steps will help to keep rust and corrosion from impairing your generator's function and appearance, and will make the engine easier to start when you use the generator again.

Cleaning

Wipe the generator with a moist cloth. After the generator has dried, touch up any damaged paint, and coat other areas that may rust with a light film of oil.

Fuel

Gasoline will oxidize and deteriorate in storage. Old gasoline will cause hard starting, and it leaves gum deposits that clog the fuel system. If the gasoline in your generator deteriorates during storage, you may need to have the carburetor and other fuel system components serviced or replaced.

The length of time that gasoline can be left in your fuel tank and carburetor without causing functional problems will vary with such factors as gasoline blend, your storage temperatures, and whether the fuel tank is partially or completely filled. The air in a partially filled fuel tank promotes fuel deterioration. Very warm storage temperatures accelerate fuel deterioration. Fuel deterioration problems may occur within a few months, or even less if the gasoline was not fresh when you filled the fuel tank.

The *Distributor's Limited Warranty* does not cover fuel system damage or engine performance problems resulting from neglected storage preparation.

You can extend fuel storage life by adding a gasoline stabilizer that is formulated for that purpose, or you can avoid fuel deterioration problems by draining the fuel tank and carburetor.

Adding a Gasoline Stabilizer to Extend Fuel Storage Life

When adding a gasoline stabilizer, fill the fuel tank with fresh gasoline. If only partially filled, air in the tank will promote fuel deterioration during storage. If you keep a container of gasoline for refueling, be sure that it contains only fresh gasoline.

1. Add fuel stabilizer following manufacturer's instructions.
2. After adding a fuel stabilizer, run the engine outdoors for 10 minutes to be sure that treated gasoline has replaced the untreated gasoline in the carburetor.
3. Stop the engine, and turn the fuel valve lever to the OFF position.

STORAGE

Draining the Fuel Tank and Carburetor

⚠ WARNING

Gasoline is highly flammable and explosive.

You can be burned or seriously injured when handling fuel.

- Stop the engine and keep heat, sparks, and flame away.
- Handle fuel only outdoors.
- Wipe up spills immediately.

1. Open the maintenance cover.
2. Place a suitable gasoline container below the carburetor drain hose.
3. Loosen the carburetor drain screw and drain the gasoline from the carburetor.
4. After all the fuel has drained into the container, tighten the drain screw securely.
5. Place an approved gasoline container below the sediment cup, and use a funnel to avoid spilling fuel. Remove the sediment cup, then move the fuel valve lever to the ON position (see page 41 – 42).
6. Allow the fuel to drain completely, then reinstall the sediment cup (see page 41 – 42).
7. Close the maintenance cover.

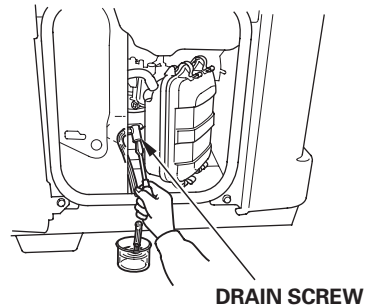

Engine Preparation

1. Change the engine oil (see page 36).
2. Remove the spark plug (see page 43).
3. Pour a tablespoon (5 – 10 cc) of clean engine oil into the cylinder.
4. Pull the starter rope several times to distribute the oil in the cylinder.
5. Reinstall the spark plug.
6. Slowly pull the starter grip until resistance is felt. At this point, the piston is coming up on its compression stroke and both the intake and exhaust valves are closed. Storing the engine in this position will help to protect it from internal corrosion. Return the starter grip gently.

STORAGE

STORAGE PRECAUTIONS

If your generator will be stored with gasoline in the fuel tank and carburetor, it is important to reduce the hazard of gasoline vapor ignition.

Select a well-ventilated storage area away from any appliance that operates with a flame, such as a furnace, water heater, or clothes dryer. Also avoid any area with a spark-producing electric motor, or where power tools are operated.

If possible, avoid storage areas with high humidity, because that promotes rust and corrosion.

Unless all fuel has been drained from the fuel tank, leave the fuel valve lever in the OFF position to reduce the possibility of leakage.

Place the generator on a level surface. Tilting can cause fuel or oil leakage.

With the engine and exhaust system cool, cover the generator to keep out dust. A hot engine and exhaust system can ignite or melt some materials.

Do not use sheet plastic as a dust cover. A nonporous cover will trap moisture around the generator, promoting rust and corrosion.

REMOVAL FROM STORAGE

Check your generator as described in the BEFORE OPERATION chapter of this manual.

If the fuel was drained during storage preparation, fill the tank with fresh gasoline. If you keep a container of gasoline for refueling, be sure that it contains only fresh gasoline. Gasoline oxidizes and deteriorates over time, causing hard starting.

If the cylinder was coated with oil during storage preparation, the engine may smoke briefly at startup. This is normal.

TRANSPORTING

If the generator has been running, allow the engine to cool for at least 15 minutes before loading the generator on the transport vehicle. A hot engine and exhaust system can burn you and can ignite some materials.

Keep the generator level when transporting to reduce the possibility of fuel leakage. Move the fuel valve lever to the OFF position.

TAKING CARE OF UNEXPECTED PROBLEMS

ENGINE PROBLEMS

Engine Will Not Start	Possible Cause	Correction
1. Check control positions.	Fuel valve lever OFF.	Turn lever ON.
	Choke knob OPEN.	Move to CLOSED unless engine is warm.
	Engine switch OFF.	Turn engine switch to ON.
2. Check fuel.	Out of fuel.	Refuel (p. 33).
	Bad fuel; generator stored without treating or draining gasoline, or refueled with bad gasoline.	Drain fuel tank and carburetor (p. 50). Refuel with fresh gasoline (p. 33).
3. Check engine oil level.	Low oil level caused Oil Alert® to stop engine.	Add oil (p. 35).
4. Remove and inspect spark plug.	Spark plug faulty, fouled, or improperly gapped.	Gap, or replace spark plug (p. 43).
	Spark plug wet with fuel (flooded engine).	Dry and reinstall spark plug.
5. Take generator to an authorized Alphagen servicing dealer, or refer to shop manual.	Fuel filter clogged, carburetor malfunction, ignition malfunction, valves stuck, etc.	Replace or repair faulty components as necessary.

TAKING CARE OF UNEXPECTED PROBLEMS

Engine Lacks Power	Possible Cause	Correction
1. Check air filter.	Air filter clogged.	Clean or replace air filter (p. 38).
2. Check fuel.	Bad fuel; generator stored without treating or draining gasoline, or refueled with bad gasoline.	Drain fuel tank and carburetor (p. 50). Refuel with fresh gasoline (p. 33).
3. Take generator to an authorized Alphagen servicing dealer, or refer to shop manual.	Fuel filter clogged, carburetor malfunction, ignition malfunction, valves stuck, etc.	Replace or repair faulty components as necessary.

TAKING CARE OF UNEXPECTED PROBLEMS

GENERATOR PROBLEMS

No Power at the DC Output Coupler	Possible Cause	Correction
1. Check output and overload indicator.	Output indicator is OFF, and overload indicator is ON.	Check DC load. Stop and restart the engine.
		Check the cooling air inlet. Stop and restart the engine.
2. Check UPS battery string voltage requirement.	Setting different voltage connected to the UPS.	Turn off the engine switch and set the voltage selector switch to the same battery string voltage of the UPS (p. 14).
3. Check the power cord.	Power cord connected to UPS battery string in reverse polarity.	Make sure generator positive output side of coupler is connected to positive terminal of UPS battery string.
4. Take generator to an authorized Alphagen servicing dealer, or refer to shop manual.	Faulty generator.	Replace or repair faulty components as necessary.

TAKING CARE OF UNEXPECTED PROBLEMS

Forced Output Function Cannot Be Used	Possible Cause	Correction
1. Check overload indicator.	Overload indicator is OFF.	Check that the power cord from the UPS is connected to the DC output coupler. If not, stop the engine and connect the power cord to the DC output coupler.
		Check the UPS battery voltage. Replace the UPS battery with a new one if the UPS battery voltage is 0 – 2 V (P. 26).
2. Check the voltmeter.	The UPS battery voltage is not in the tolerance level for the forced output.	Check the UPS battery voltage. Forced output will only operate if the battery voltage is sufficient. (P. 26).
3. Restart the engine.	The protection function is operating or the output switch has been used to stop the generator output.	To reset , stop and restart the engine.
4. Take generator to an authorized Alphagen servicing dealer, or refer to shop manual.	Faulty generator.	Replace or repair faulty components as necessary.

TECHNICAL & CONSUMER INFORMATION

TECHNICAL INFORMATION

Serial Number Location

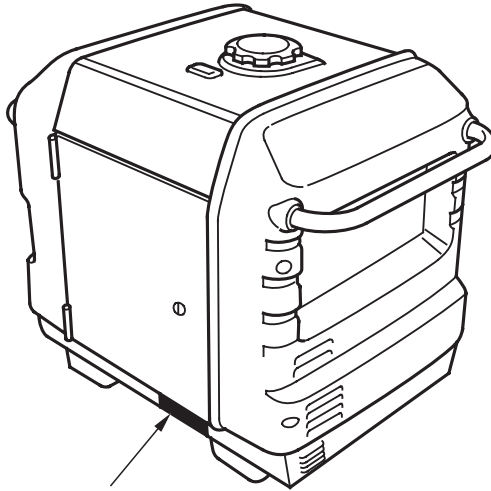

FRAME SERIAL NUMBER

Record the frame serial number in the space below. You will need this serial number when ordering parts, and when making technical or warranty inquiries.

Frame serial number: _____

Date purchased: _____

Carburetor Modification for High Altitude Operation

At high altitude, the standard carburetor air-fuel mixture will be too rich. Performance will decrease, and fuel consumption will increase. A very rich mixture will also foul the spark plug and cause hard starting. Operation at an altitude that differs from that at which this engine was certified, for extended periods of time, may increase emissions.

High altitude performance can be improved by specific modifications to the carburetor. If you always operate your generator at altitudes above 5,000 feet (1,500 meters), have your authorized Alphagen servicing dealer perform this carburetor modification. This engine, when operated at high altitude with the carburetor modifications for high altitude use, will meet each emission standard throughout its useful life.

Even with carburetor modification, engine horsepower will decrease about 3.5% for each 1,000-foot (300-meter) increase in altitude. The effect of altitude on horsepower will be greater than this if no carburetor modification is made.

NOTICE

When the carburetor has been modified for high altitude operation, the air/fuel mixture will be too lean for low altitude use. Operation at altitudes below 5,000 feet (1,500 meters) with a modified carburetor may cause the engine to overheat and result in serious engine damage. For use at low altitudes, have your servicing dealer return the carburetor to original factory specifications.

TECHNICAL & CONSUMER INFORMATION

Oxygenated Fuels

Some conventional gasolines are being blended with alcohol or an ether compound. These gasolines are collectively referred to as oxygenated fuels. To meet clean air standards, some areas of the United States and Canada use oxygenated fuels to help reduce emissions.

If you use an oxygenated fuel, be sure it is unleaded and meets the minimum octane rating requirement.

Before using an oxygenated fuel, try to confirm the fuel's contents. Some states/provinces require this information to be posted on the pump.

The following are the EPA approved percentages of oxygenates:

ETHANOL ——— (ethyl or grain alcohol) 10% by volume
You may use gasoline containing up to 10% ethanol by volume. Gasoline containing ethanol may be marketed under the name Gasohol.

MTBE ————— (Methyl Tertiary Butyl Ether) 15% by volume
You may use gasoline containing up to 15% MTBE by volume.

METHANOL ——— (methyl or wood alcohol) 5% by volume
You may use gasoline containing up to 5% methanol by volume as long as it also contains cosolvents and corrosion inhibitors to protect the fuel system. Gasoline containing more than 5% methanol by volume may cause starting and/or performance problems. It may also damage metal, rubber, and plastic parts of your fuel system.

If you notice any undersirable operating symptoms, try another service station, or switch to another brand of gasoline.

Fuel system damage or performance problems resulting from the use of an oxygenated fuel containing more than the percentages of oxygenates mentioned above are not covered under warranty.

Emission Control System Information

Source of Emissions

The combustion process produces carbon monoxide, oxides of nitrogen, and hydrocarbons. Control of hydrocarbons and oxides of nitrogen is very important because, under certain conditions, they react to form photochemical smog when subjected to sunlight. Carbon monoxide does not react in the same way, but it is toxic.

Honda uses lean carburetor settings and other systems to reduce the emissions of carbon monoxide, oxides of nitrogen, and hydrocarbons.

The U.S. and California Clean Air Acts

EPA and California regulations require all manufacturers to furnish written instructions describing the operation and maintenance of emission control systems.

The following instructions and procedures must be followed in order to keep the Honda engine emissions within the emission standards.

Tampering and Altering

Tampering with or altering the emission control system may increase emissions beyond the legal limit. Among those acts that constitute tampering are:

- Removal or alteration of any part of intake, fuel, or exhaust systems.
- Altering or defeating the governor linkage or speed-adjusting mechanism to cause the engine to operate outside its design parameters.

TECHNICAL & CONSUMER INFORMATION

Problems That May Affect Emissions

If you are aware of any of the following symptoms, have your engine inspected and repaired by your authorized Alphagen servicing dealer.

- Hard starting or stalling after starting.
- Rough idle.
- Misfiring or backfiring under load.
- Afterburning (backfiring).
- Black exhaust smoke or high fuel consumption.

Replacement Parts

The emission control systems on your new Honda engine were designed, built, and certified to conform with EPA and California emission regulations. We recommend the use of genuine Honda parts whenever you have maintenance done. These original-design replacement parts are manufactured to the same standards as the original parts, so you can be confident of their performance. The use of replacement parts that are not of the original design and quality may impair the effectiveness of your emission control system.

A manufacturer of an aftermarket part assumes the responsibility that the part will not adversely affect emission performance. The manufacturer or rebuilder of the part must certify that use of the part will not result in a failure of the engine to comply with emission regulations.

Maintenance

Follow the Maintenance Schedule on page 32. Remember that this schedule is based on the assumption that your machine will be used for its designed purpose. Sustained high-load or high-temperature operation, or use in dusty conditions, will require more frequent service.

TECHNICAL & CONSUMER INFORMATION

Air Index

An Air Index Information hang tag/label is applied to engines certified to an emission durability time period in accordance with the requirements of the California Air Resources Board.

The bar graph is intended to provide you, our customer, the ability to compare the emissions performance of available engines. The lower the Air Index, the less pollution.

The durability description is intended to provide you with information relating to the engine's emission durability period. The descriptive term indicates the useful life period for the engine's emission control system. See your *Emission Control System Warranty* for additional information.

Descriptive Term	Applicable to Emissions Durability Period
Moderate	50 hours (0 – 65 cc) 125 hours (greater than 65 cc)
Intermediate	125 hours (0 – 65 cc) 250 hours (greater than 65 cc)
Extended	300 hours (0 – 65 cc) 500 hours (greater than 65 cc)

The Air Index Information hang tag must remain on the generator until it is sold. Remove the hang tag before operating the generator.

TECHNICAL & CONSUMER INFORMATION

Specifications

Dimensions

Model	DCX3000
Power product description code	EAMJ
Length	25.8 in (655 mm)
Width	17.5 in (445 mm)
Height	21.9 in (555 mm)
Dry weight	117 lbs (53 kg)

Engine

Model	GX200	
Engine Type	4-stroke, overhead valve, single cylinder	
Displacement	12.0 cu-in (196 cm ³)	
Bore x Stroke	2.7 × 2.1 in (68 × 54 mm)	
Compression Ratio	8.5:1	
Engine Speed	at 39.5V	2,500 – 3,300 rpm
	at 52.5V	2,800 – 3,600 rpm
Cooling System	Forced air	
Ignition System	Transistorized magneto	
Oil Capacity	0.58 US qt (0.55 ℓ)	
Fuel Tank Capacity	3.43 US gal (13.0 ℓ)	
Spark Plug	BPR5ES (NGK) W16EPR-U (DENSO)	

Generator

DC output	Rated voltage	39.5/52.5 V
	Rated Ampere	70.8/53.3 A
	Rated Output	2.8 kW
	Maximum Output	3.0 kW

Tuneup Specifications

ITEM	SPECIFICATION	MAINTENANCE
Spark plug gap	0.028 – 0.031 in (0.70 – 0.80 mm)	Refer to page: 43
Valve clearance (cold)	IN: 0.15 ± 0.02 mm EX: 0.20 ± 0.02 mm	See your authorized Alphagen dealer
Other specifications	No other adjustments needed.	

Specifications may vary according to the types, and are subject to change without notice.

TECHNICAL & CONSUMER INFORMATION

Wiring Diagram

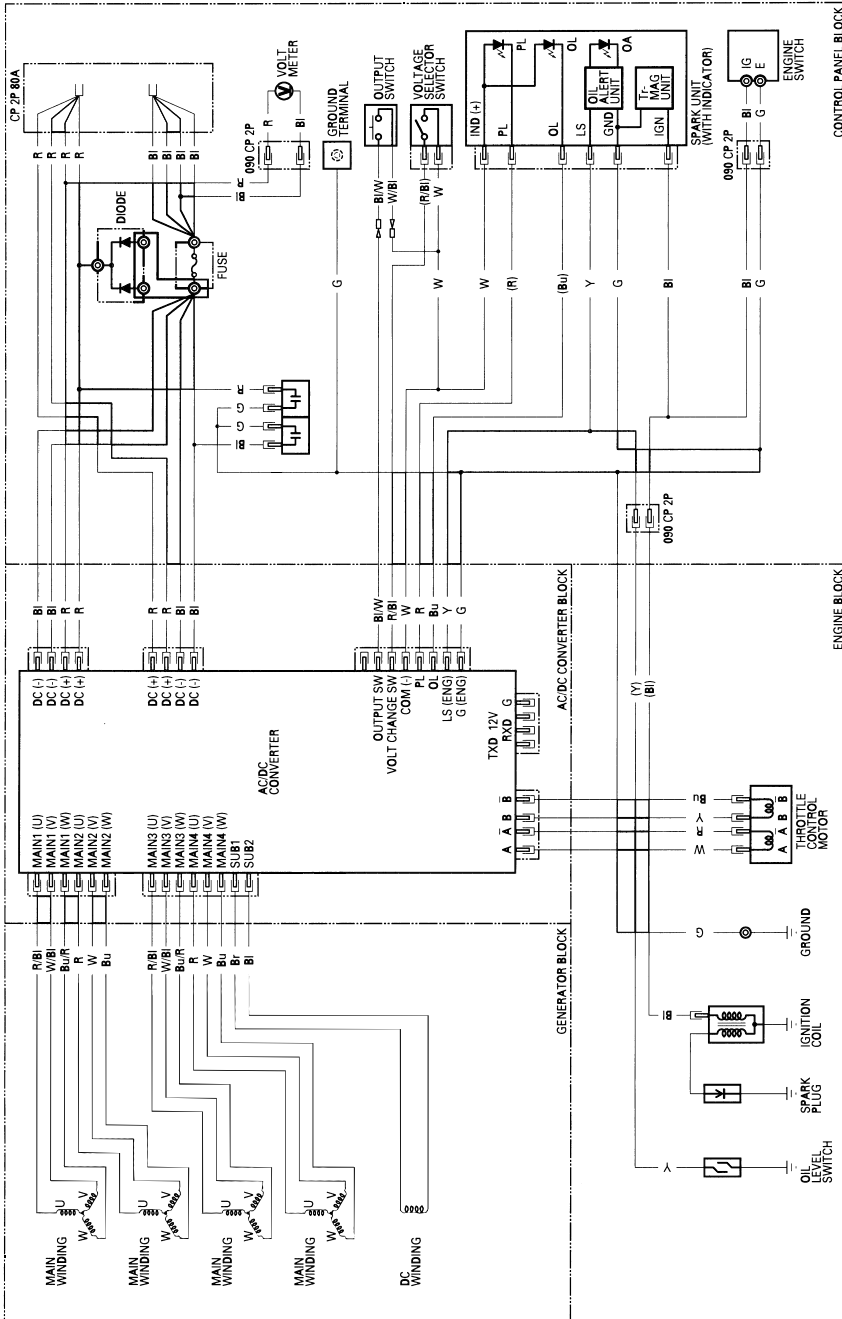

B	BLACK
BR	BROWN
BL	BLUE
GR	GREEN
OR	ORANGE
RD	RED
PK	PINK
GY	GRAY
W	WHITE

COLOR CODE - GROUND MARKING

VOLT CHANGE SWITCH CONNECTION TABLE	
TERMINAL	VOLT
COM	38.5V
PA	52.5V
AMP	52.5V
ON	

ENGINE SWITCH CONNECTION TABLE	
IG	E
ON	
OFF	

TECHNICAL & CONSUMER INFORMATION

CONSUMER INFORMATION

Publications

These publications will give you additional information for maintaining and repairing your generator. You may order them from your Alphagen dealer.

Shop Manual

This manual covers complete maintenance and overhaul procedures. It is intended to be used by a skilled technician.

Parts Catalog

This manual provides complete, illustrated parts lists.

TECHNICAL & CONSUMER INFORMATION

Customer Service Information

Alpha Technologies
3767 Alpha Way
Bellingham, WA 98226
(360) 647-2360

For general product information and customer service
7:00AM to 5:00PM Pacific Time
1-800-863-3930

To obtain complete Technical Support
7:00AM to 5:00PM Pacific Time
or
For after-hours Emergency Support
7 days per week, 24 hours a day
1-800-863-3364

INDEX

A	
	AIR CLEANER SERVICE.....38
	Air index.....63
	ARE YOU READY TO GET STARTED ?20
B	
	BEFORE OPERATION20
C	
	Carbon Monoxide Hazards.....6
	Carburetor Modification for High Altitude Operation59
	Check the engine21
	Choke knob15
	Cleaning48
	COMPONENT & CONTROL LOCATIONS12
	CONSUMER INFORMATION66
	CONTROLS14
	CONTROLS & FEATURES.....12
	Customer Service information.....67
D	
	DC Operation23
	DC Output Coupler17
	DC Voltage Selector Switch.....14

E	
EcoThrottle™ System	17
Electric Shock Hazards.....	7
Emission Control System Information	61
Engine Preparation.....	51
ENGINE OIL CHANGE	36
ENGINE OIL LEVEL CHECK.....	35
ENGINE OIL RECOMMENDATIONS	37
ENGINE PROBLEMS.....	54
Engine Switch	15
F	
FEATURES	17
Fire and Burn Hazards.....	7
FOAM AIR FILTER CLEANING	40
Forced Output.....	26
Fuel	48
Fuel Gauge.....	19
FUEL RECOMMENDATIONS	34
Fuel Valve Lever	14
G	
GENERATOR PROBLEMS.....	56
GENERATOR SAFETY	6
Ground Terminal	17

INDEX

I	
	IMPORTANT SAFETY INFORMATION.....6
	INDEX.....68
	IS YOUR GENERATOR READY TO GO ?20
K	
	Knowledge.....20
M	
	MAINTENANCE SAFETY31
	MAINTENANCE SCHEDULE.....32
O	
	Oil Alert® Indicator.....19
	OPERATION22
	Operator Responsibility.....6
	Output Indicator18
	Output Switch.....16
	Overload Indicator.....18
	Oxygenated Fuels.....60
P	
	Publications66
Q	
	QUICK REFERENCE INFORMATIONInside back cover
R	
	Recoil Starter16
	REFUELING33
	Refuel With Care.....8
	REMOVAL FROM STORAGE52

S	
	SAFE OPERATING PRECAUTIONS.....22
	SAFETY LABEL LOCATIONS.....9
	Safety Precautions31
	SEDIMENT CUP CLEANING41
	Serial Number Location58
	SERVICING YOUR GENERATOR30
	Specifications64
	SPARK ARRESTER SERVICE45
	SPARK PLUG SERVICE43
	STARTING THE ENGINE.....23
	STOPPING THE ENGINE.....28
	STORAGE48
	STORAGE PRECAUTIONS52
	STORAGE PREPARATION.....48
T	
	TAKING CARE OF UNEXPECTED PROBLEMS54
	TECHNICAL INFORMATION.....58
	TECHNICAL & CONSUMER INFORMATION.....58
	THE IMPORTANCE OF MAINTENANCE.....30
	TRANSPORTING53
V	
	Voltmeter17
W	
	Wiring Diagram.....65

MEMO

QUICK REFERENCE INFORMATION

Fuel	Type	Unleaded gasoline with a pump octane rating of 86 or higher
Spark Plug	Type	NGK: BPR5ES (NGK) DENSO: W16EPR-U (DENSO)
	Electrode Gap	0.028 – 0.031 in (0.70 – 0.80 mm)
Maintenance	Before each use	Check engine oil level. Check air filter.
	First 20 hours	Change engine oil.
	Subsequent	See Maintenance Schedule (page 32)

31ZS9700
00X31-ZS9-7000

(AH) (英) (C) (HC) 1000.2004.10
(EM3) (Hi) Printed in Japan